

CODERS

B.V. Korthofah
Lageweg 39
P.O. box 3040
2220 CA KATWIJK (ZH)
THE NETHERLANDS
Telephone: *31 (0)71-4060470
Fax: *31 (0)71-4032807

Article reference: H302 AE

1	GENERAL INSTRUCTIONS BEFORE USE	5
1.1	Responsibility	5
1.2	Lifespan	5
1.3	Regular use	5
1.4	Environment	5
1.5	Operating personnel	7
2	SAFE USE	9
2.1	General precautions	9
3	KORTHO CODER WITH EXCHANGEABLE TEXTROLL, MODELS IS AND KL	11
4	KORTHO PLAINCODER, MODEL ISP	25
5	THE INKPUMP	37
6	KORTHO HIGH-SPEED-CODER, MODELS HS AND HSD	43
7	KORTHO HANDCODER WITH EXCHANGEABLE TEXTROLL, MODELS IS AND KL	53
8	HANDCODER, MODEL ERP	63
	APPENDIX A: Ink schedule	69
	APPENDIX B: Technical details	73
	APPENDIX C: Survey mounting-possibilities high-speed coders	77
	APPENDIX D: Dimensional diagrams	81
	APPENDIX E: Spare parts	89
	EG-declaration of agreement	99

At the beginning of each chapter a detailed index is given for the respective chapter.

1 GENERAL INSTRUCTIONS BEFORE USE

Please carefully read the chapters of this manual relating to your coder equipment before putting them into use. Chapters 1 and 2 are applicable for all coding devices mentioned in this manual.

While performing the prescribed actions you need to strictly follow the indicated sequence.

Take very good notice of all warnings!

1.1 Responsibility

B.V. Korthofah does not accept any liability for damages resulting from an incorrect or wrong use of the equipment, nor for damages resulting from incorrectly performed maintenance or other operations.

No liability is accepted for the normal wear of the product.

1.2 Lifespan

The lifespan of the coding equipment during normal use and the following indicated maintenance terms, is ten years. The use of non-original parts for repairs may have a negative influence on the lifespan of the product. This will also nullify the guarantee and any claims for compensation.

The coding equipment does not contain any harmful substances or materials and may be recycled or converted into scrap at the end of its lifespan.

The used stamping foil and inkcontainers may be disposed of as small chemical waste.

Please note: the above mentioned is based upon legislation effective mid-1995.

1.3 Regular use

Regular use means use under normal circumstances, that is within the within this manual indicated margins.

1.4 Environment

The environment in which to install the coding equipment must meet with a number of demands as to humidity, temperature and vibrations.

The relative humidity has to be between 0 and 85% (non-condensating).
The environmental temperature should be between -10 and 40 °C.
It is not allowed to use the coders in environments with fire or explosion hazards.
The coders should be mounted so that they won't be exposed to vibrations.

1.5 Operating personnel

Operating personnel need to be instructed on the functioning of the coding equipment. They also need to be familiar with the warnings and advices of this manual.
No specific prior education is required.

Personnel performing repairs of the coding equipment need to have completed a secondary school-level technical education, or should have a similar technical know-how due to professional experience.

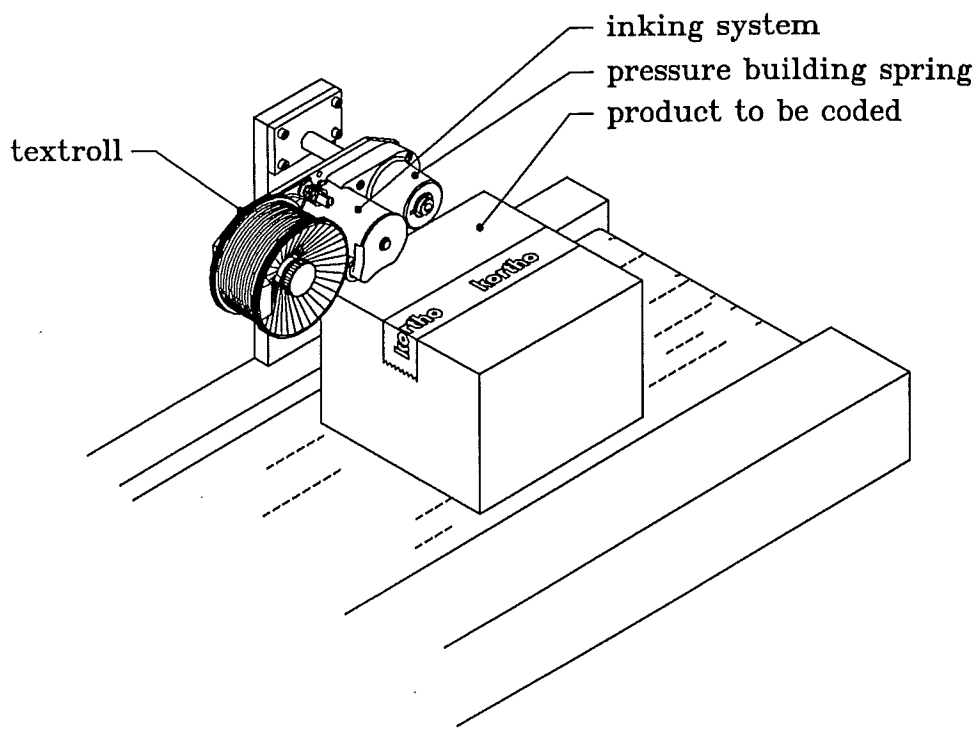

Figure 1 : A Kortho-coder

2 SAFE USE

The coding equipment is solid and reliable. In order to use it safely it is important to strictly follow the precautions indicated in this manual.

2.1 General precautions (see figure 1)

The functioning of the coding equipment is based upon:

- movement (of the textroll);
- pressure (between the textroll and the product);

In the aforementioned statements lie the potential dangers of the coding equipment. In order to prevent dangerous situations, here follow the most important precautions.

- Stop the supply of products or foil to be coded before performing maintenance on the coding equipment (such as: replacing/augmenting ink, changing texts and repairs);
- Be careful not to get trapped between the coding equipment and its surroundings. The correct way for setting it up is indicated in the manual.

3	KORTHO CODER WITH REPLACEABLE TEXTROLL, MODELS IS AND KL	
3.1	GENERAL INTRODUCTION	13
3.2	MOUNTING INSTRUCTIONS	13
3.2.1	Vertical setting	13
3.2.2	Horizontal setting	13
3.3	ADJUSTING THE KORTHO CODER	15
3.3.1	Adjusting the torque-spring	15
3.3.2	Adjusting the excenter mechanism	15
3.4	THE TEXTROLL	15
3.4.1	Adjusting the textroll	15
3.4.2	Positioning the text on the product	17
3.4.3	Exchanging textrolls	17
3.5	INSERTING AND REPLACING TYPE	17
3.6	INK AND SOLVENTS	17
3.6.1	The inking system with liquid ink	19
3.6.1.1	Inking the ink container when putting in use	19
3.6.1.2	Re-inking the ink container	19
3.6.2	The Kortho Lon inking system	21
3.7	PREVENTIVE MAINTENANCE	21
3.7.1	Cleaning	21
3.7.2	Checking the running bands	21
3.7.3	Checking the inking system	21
3.7.4	Checking the greasing-points	21
3.7.5	Greasing the coder	23

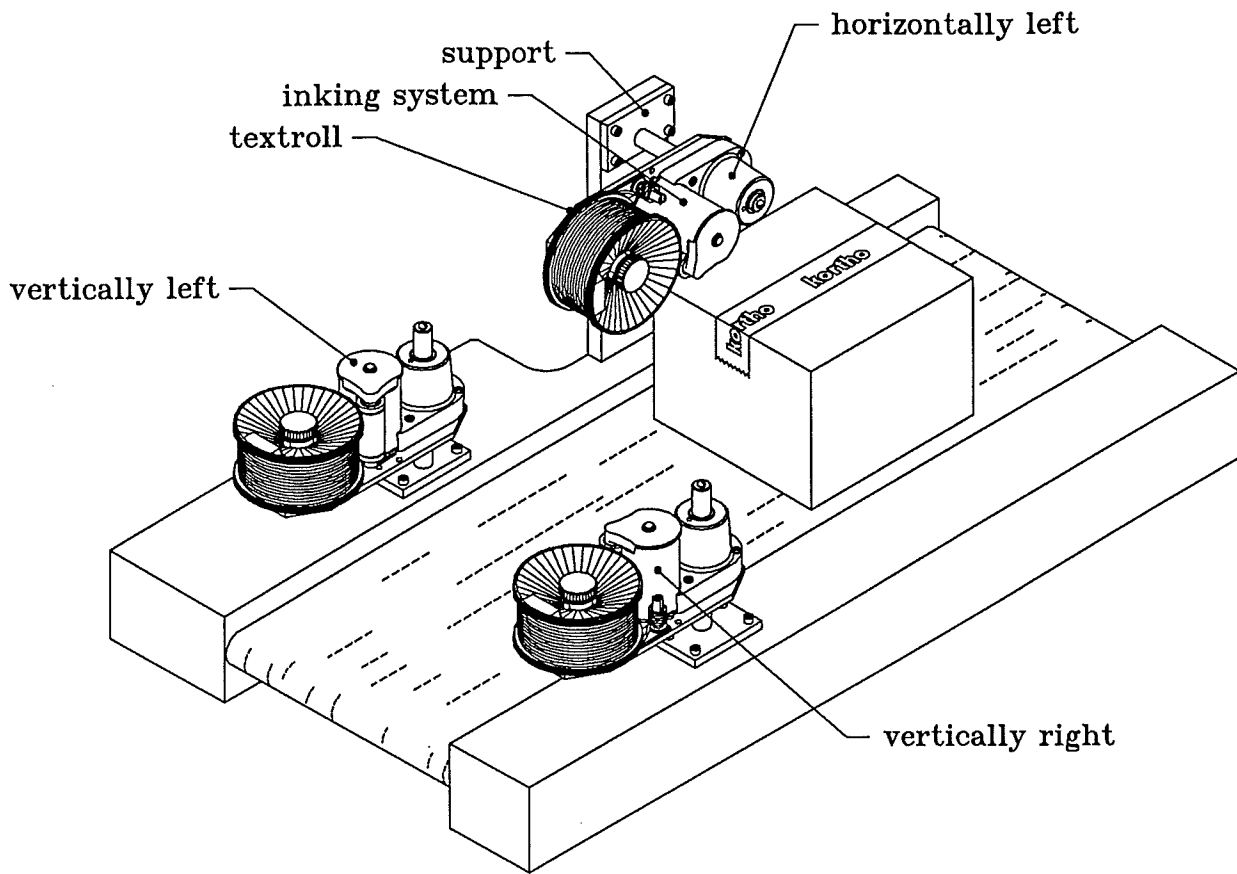

Figure 2 : Mounting possibilities for Kortho-coders

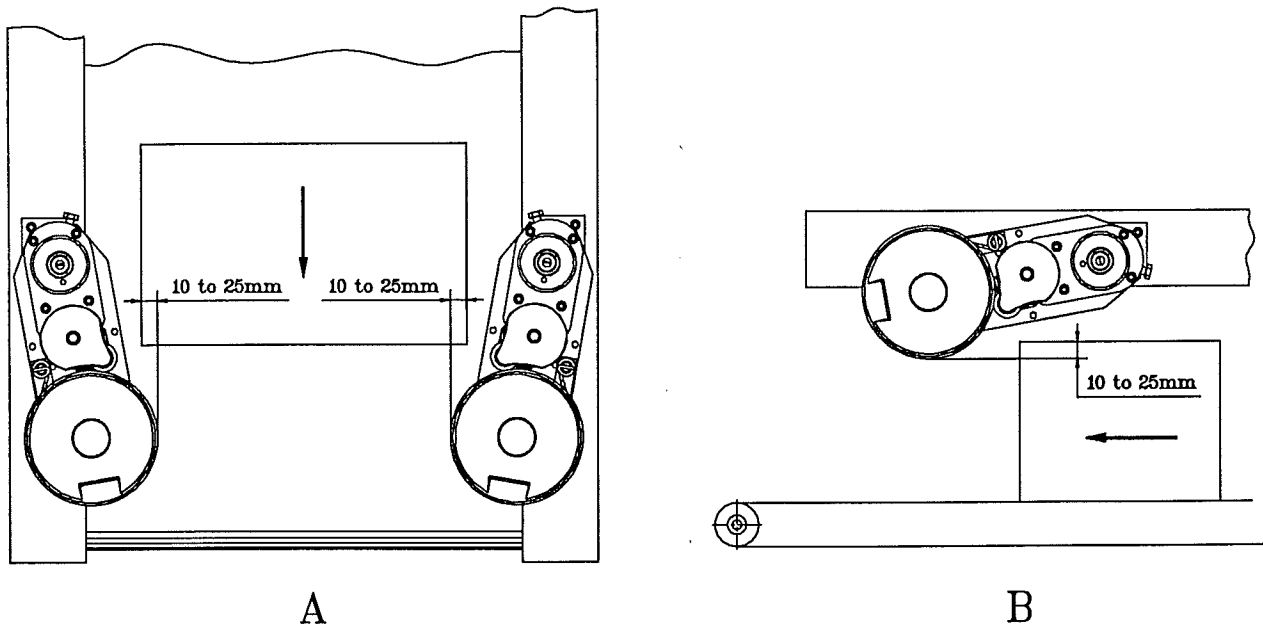

Figure 3 : Coders position towards the product

3 KORTHO CODER WITH REPLACEABLE TEXTROLL, MODELS IS AND KL

3.1 GENERAL INTRODUCTION

(see figure 2)

Kortho Coders have been developed for coding products in line. According to the mounting position a right or a left model is to be selected.

The image to be imprinted is by means of rubber type applied on a exchangeable textroll. The system is being inked by means of a cartridge (model KL - Kortho Lon) or through liquid ink (model IS), possibly supplied through a separately available ink pump.

3.2 MOUNTING INSTRUCTIONS

(see figure 2)

See figure 2 for a survey of the mounting possibilities.

When mounting pay attention to the free space around the coder and place it so there is no chance of getting caught between the functioning coder and its surroundings (NEN-EN 294 and 349). Also keep in mind the possibility of mounting an ink pump later.

3.2.1 Vertical setting

(see figure 3A)

1. Drill the mounting-holes for the support at the desired place on your machine or conveyor belt (diameter 6,5mm. or M6). Drill the holes at centres of 40 x 80mm.
2. Mount the support with bolts M6 (4x).
3. Attach the coder in the right position to the support. The coder should be 10 to 25 mm. into the product's path.

3.2.2 Horizontal setting

(see figure 3B)

1. Drill the mounting-holes for the support at the desired place on your machine or conveyor belt (diameter 6,5mm. or M6). Drill the holes at centres of 40 x 80mm.
2. Mount the support with bolts M6 (4x).
3. Attach the coder in the right position to the support. The coder should be 10 to 25 mm. into the product's path.

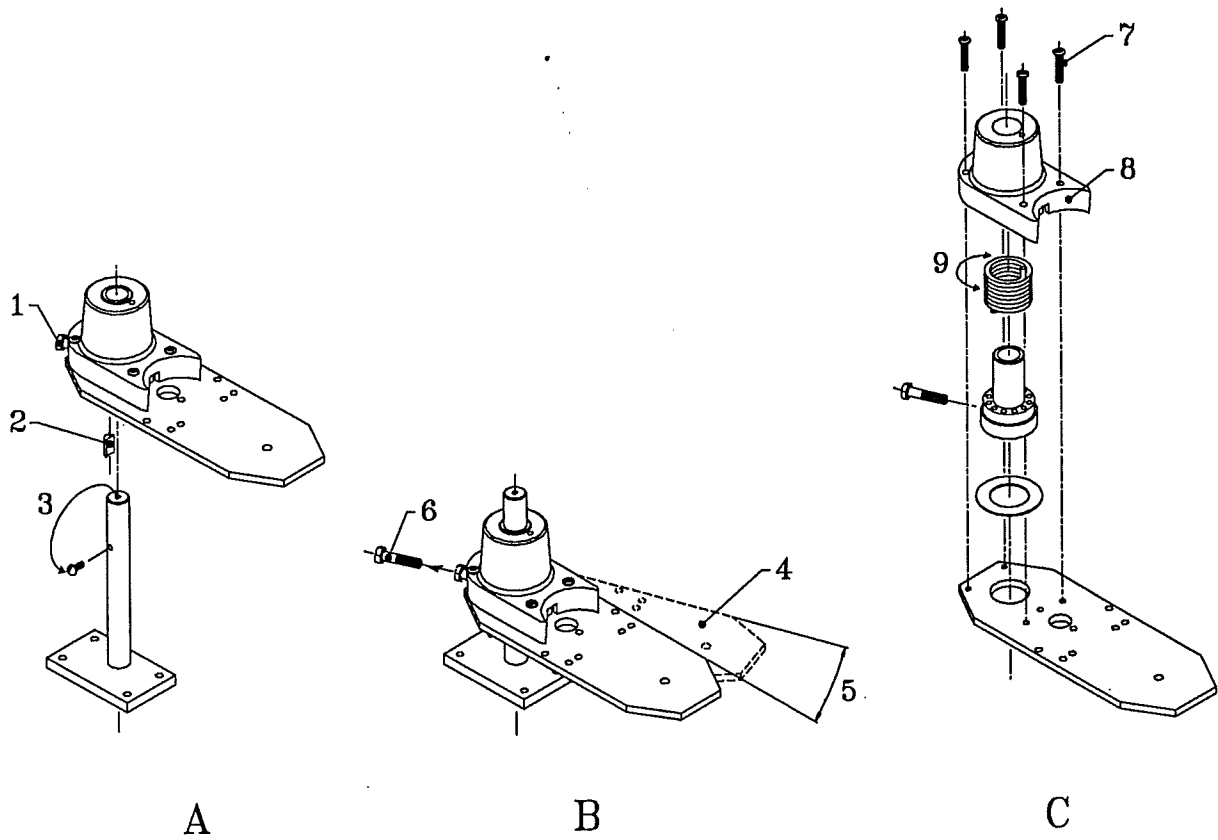

Figure 4 : Adjusting the torque-spring

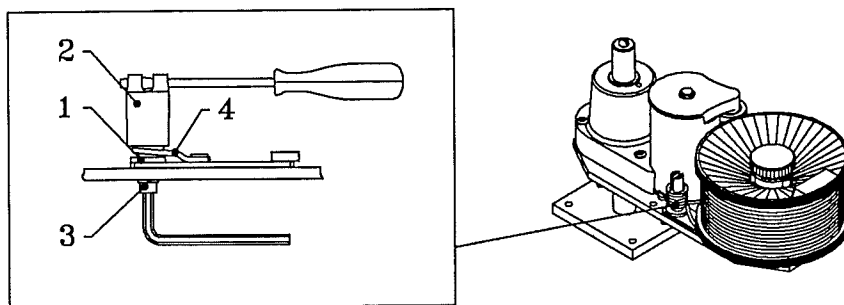

Figure 5 : Adjusting the excenter mechanism

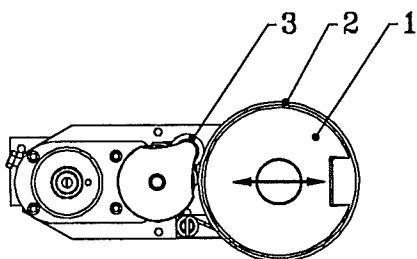

Figure 6 : Adjusting the textroll

3.3 ADJUSTING THE KORTHO CODER

3.3.1 Adjusting the torque-spring

(see figure 4)

The torque-spring makes the textroll press against the surface to be imprinted. If the print turns out to be too bold or too vague the torque-spring will need adjustment.

1. Remove the coder from the support turning loose the bolt (1).
2. Remove the pressure plate (2).
3. Turn loose screw (3) at the upper side of the support and place it inside the hole at the side of the support.
4. Place the coder on the support, in such a way that the screw head will fall into the opening of the pressure plate.
5. Tension the torque-spring by twisting the coder (4+5).
6. Remove the bolt (6).
7. Take the pressure off the torque-spring.
8. Remove the 4 bolts (7).
9. Remove the cover (8).
10. Place the torque-spring in the desired position (9).
11. Mount the coder in reversed order.

3.3.2 Adjusting the excenter mechanism

(see figure 5)

The excenter spring returns the textroll to its zero-position after coding a product. The excenter spring needs to be tensioned as little as possible, in order to enable a smooth rotation of the textroll.

1. Block the axis (1) with the supplied spanning tools (2).
2. Turn loose the bolt (3).
3. Set the spring (4) to the required tension.
4. Tighten the bolt.

3.4 THE TEXTROLL

3.4.1 Adjusting the textroll

(see figure 6)

Manually check (before using!) whether the inking system's rolls are rotating smoothly. If this is not the case the textroll's position needs adjusting. The textroll (1) has to be mounted so the running bands (2) precisely touch the inkdistributor-roll (3). In that case the inkdistributor-roll will smoothly rotate together with the textroll.

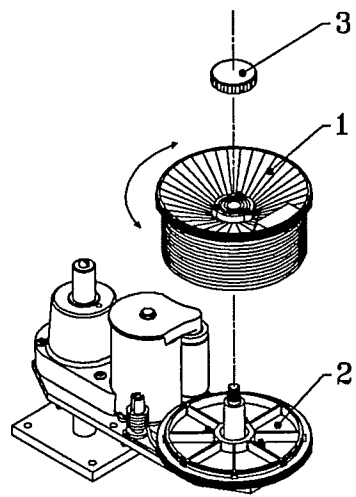

Figure 7 : Positioning the text

3.4.2 Positioning the text on the product (see figure 7)

Changing the textroll's (1) position on the lower disk (2) allows you to change the position of the print on the product. The textroll is equipped with notches, into which the ridges on the lower disk fit. With these the textroll can be rotated and fixed in steps of 45 degrees.

1. Turn loose the bolt (3).
2. Rotate the textroll into a desired position.
3. Tighten the bolt.

3.4.3 Exchanging textrolls

Exchanging textrolls is a very fast means of changing the printing text.

1. Turn loose the bolt.
2. Take the textroll off of the coder.
3. Place the new textroll (pay attention to the position of the text!).
4. Tighten the bolt.

3.5 INSERTING AND REPLACING TYPE

The textroll is covered with a rubber baseplate which has a special profile. The type has the same profile on the reverse side. With one simple pressing movement the type is attached to the textroll.

TIP:

Moisten the side with the profile with water in order to facilitate attaching larger type.

In order to remove a type, simply pull it off of the textroll.

3.6 INK AND SOLVENTS

WARNING:

The ink and solvents that are used may be a hazard to the health when used incorrectly.

For a correct use and possible precautions see the indications on the packaging.

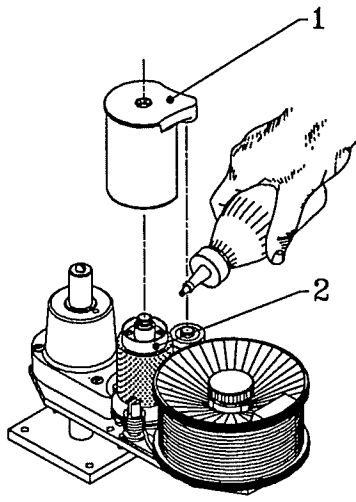

A

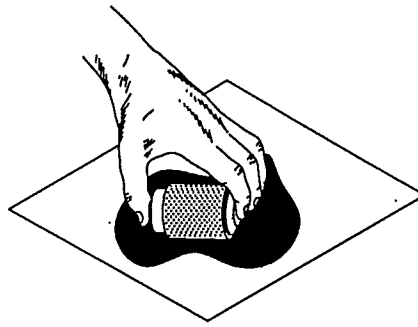

B

Figure 8 : Inking the ink container

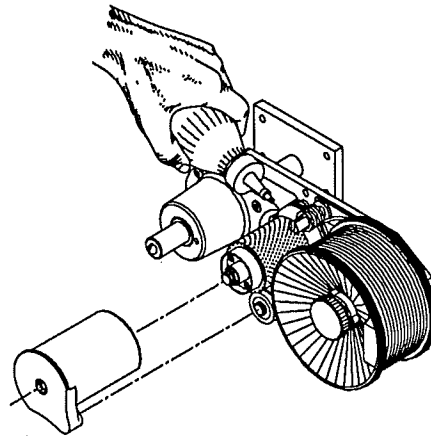
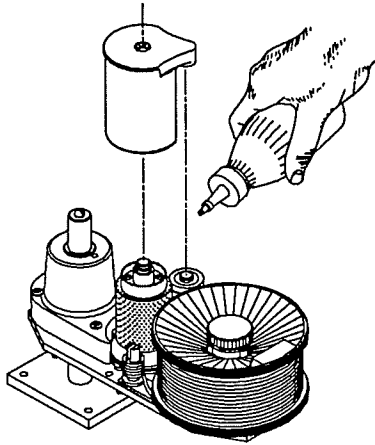

Figure 9 : Re-inking the ink container

Data-sheets with the types of ink and solvents are at request available at B.V. Korthofah.

WARNING:

With the Kortho Coders only specially designed Kortho inks are to be used.

NOTICE:

Solvent is only to be used for the cleaning of the Kortho coder and never for diluting ink!

Depending on the application this may be a quick drying ink (for non-porous surfaces) or a slow drying ink (for porous surfaces).

A special solvent is available for each sort of ink. Check with the ink schedule (see appendix A) to decide on which solvent to use.

If your coder is equipped with the Kortho Lon inking system (model KL), proceed to 3.6.2.

3.6.1 The inking system with liquid ink

3.6.1.1 Inking the ink container when putting in use (see figure 8)

1. Remove the inking cover (1).
2. Take the ink container (2) off of the coder.
3. Impregnate the ink container with ink (see figure 8b).
4. Reinsert the ink container into the coder.
5. Replace the inking cover.

3.6.1.2 Re-inking the ink container (see figure 9)

WARNING:

Be careful not to overink!

In order to re-ink the ink container remove the inking cover and directly apply the correct amount of ink to the ink container.

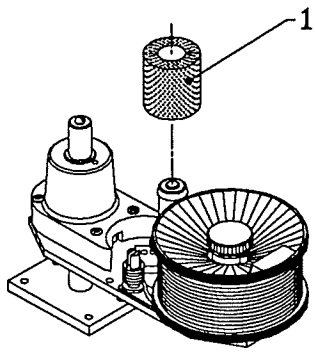

Figure 10 : Kortho-lon inking system

3.6.2 The Kortho-Lon inking system (see figure 10)

The Kortho Lon inking system uses an impregnated ink cartridge (1). This cartridge can **not be refilled** but needs to be replaced with a new one. After its use the old cartridge may be treated as small chemical waste.

TIP:

While placing a new inkroll the textroll may be marked. To prevent this while replacing the ink cartridge place a small piece of plastic foil between the textroll and the new cartridge.

3.7 PREVENTIVE MAINTENANCE

The following maintenance periods have been set for a normal use of the coding equipment. When under more extreme operating conditions it may prove necessary to modify these according to ones own experience.

3.7.1 Cleaning

Clean all parts of the coder regularly (at least once a week). Doing so use only the right kind of solvent (see ink schedule in appendix A).

3.7.2 Checking the running bands

Prevent wear of the type by regularly (at each maintenance service) checking the textroll's rubber running bands for possible wear and intactness. If necessary replace them.

3.7.3 Checking the inking system

Regularly check the inking system rolls on intactness. This check must be performed before each inking and/or with each replacement of the inkroll.

3.7.4 Checking the greasing points (see figure 11)

Regularly (twice a year) check the coders greasing points (A - E)

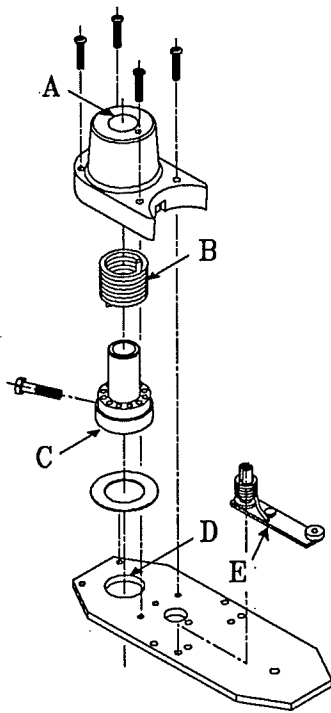

Figure 11 : Greasing points

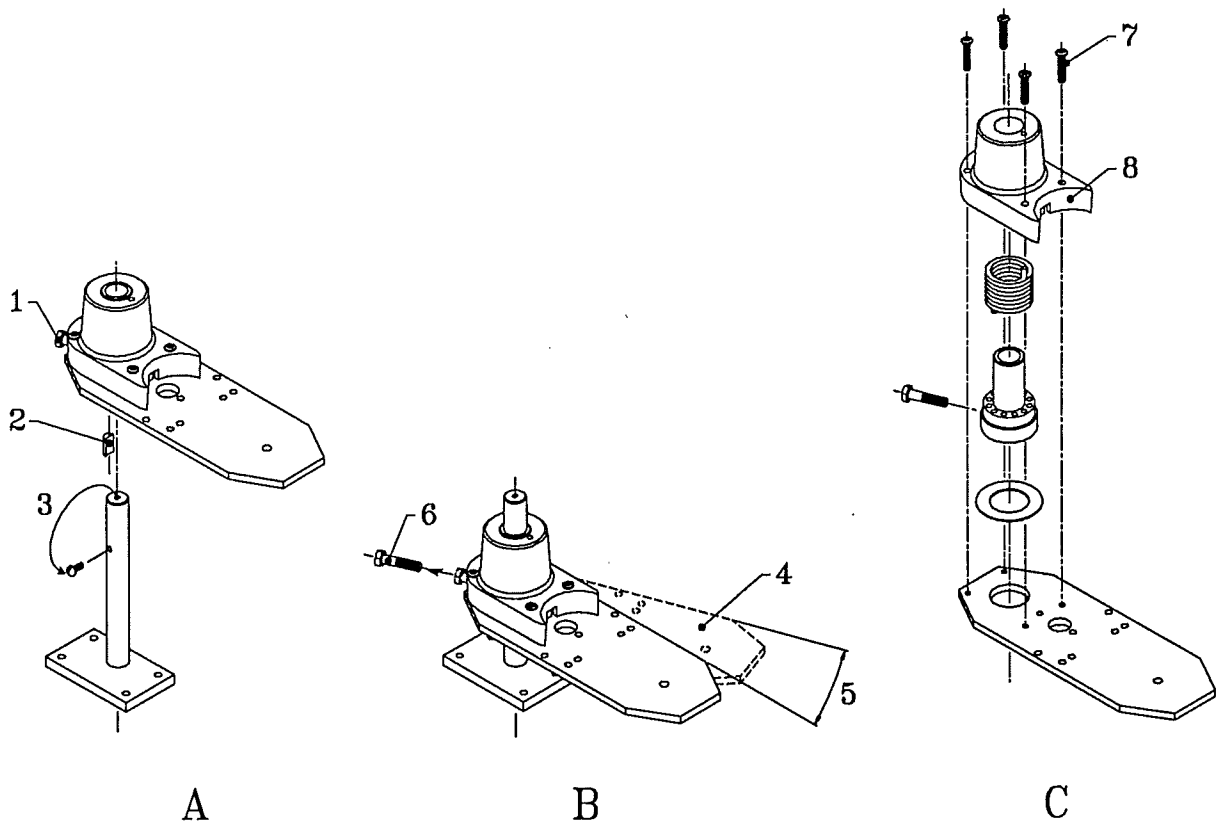

Figure 12 : Greasing the coder

3.7.5 Greasing the coder

(see figures 11 and 12)

Greasing the torque-spring

1. Take the coder from the support removing the bolt (1).
2. Remove the pressure plate (2).
3. Turn loose the screw (3) at the upper side of the support and screw it into the hole at the reverse side of the support.
4. Place the coder in such a way on the support, that the screw head will fall into the notch of the pressure plate (see figure 12).
5. Adjust the tension of the torque-spring by rotating the coder (4+5).
6. Remove the bolt (6).
7. Release the torque-spring.
8. Remove the four bolts (7)
9. Remove the cover (8).
10. Grease points A, B, C en D with grease (see figure 11)
11. Mount the coder in reverse order.

Greasing the excenter mechanism:

The excenter mechanism is greased by putting a drop of oil on point E.

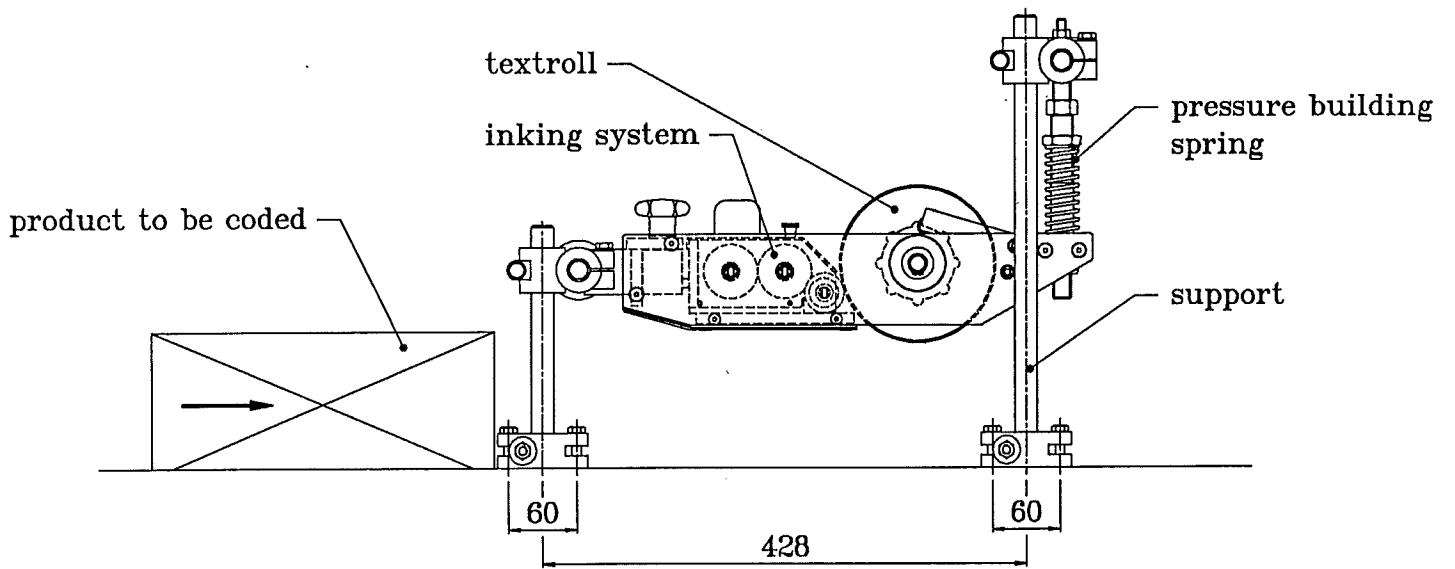
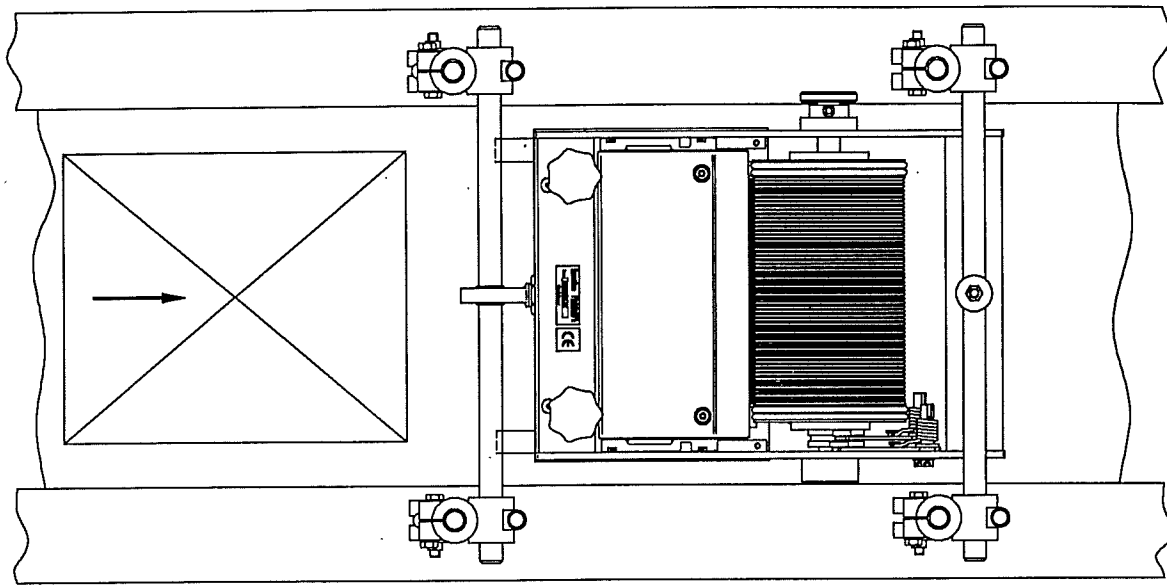

Figure 13 : The plaincoder

4	KORTHO PLAINCODER, MODEL ISP	
4.1	GENERAL INTRODUCTION	27
4.2	MOUNTING INSTRUCTIONS	27
4.2.1	Positioning the plaincoder	27
4.2.2	Mounting the plaincoder	27
4.3	ADJUSTING THE PAINCODER	29
4.3.1	Adjusting the height	29
4.3.2	Adjusting the stamping pressure	29
4.3.3	Adjusting the excenter mechanism	29
4.4	THE TEXTROLL	29
4.4.1	Removing the textroll	29
4.4.2	Inserting the textroll	31
4.4.3	Positioning the text on the product	31
4.5	INSERTING AND REMOVING TYPE	31
4.6	INK AND SOLVENTS	31
4.7	THE INKING SYSTEM	33
4.7.1	Inking the coder when putting in use	33
4.7.2	Re-inking the inkcontainers	33
4.8	PREVENTIVE MAINTENANCE	35
4.8.1	Cleaning	35
4.8.2	Checking the running bands	35
4.8.3	Checking the inking system	35
4.8.4	Greasing the excenter mechanism	35

4 KORTHO PLAINCODER, MODEL ISP

4.1 GENERAL INTRODUCTION

(see figure 13)

The Kortho Plaincoder has been developed for coding products on line. Due to the special suspension of the coder even products with a somewhat irregular form can be correctly imprinted. The Plaincoder can function only horizontally. By means of rubber type the text for the print is applied on a replaceable textroll. The system is inked with liquid ink.

4.2 MOUNTING INSTRUCTIONS

(see figure 13)

Consult figure 13 for the mounting instruction. When mounting pay attention to the free space around the coder and place it so there will be no chance of getting caught between the functioning coder and its surroundings (NEN-EN 294 and 349). Also keep in mind the possibility of mounting an ink pump later.

4.2.1 Positioning the Plaincoder

(see figure 13)

The transportation direction of the products decides the position in which the coder has to be mounted. Figure 13 indicates how to mount the coder if the product passes by in the direction of the arrow. Once the correct positioning has been established, the coder may be mounted.

4.2.2 Mounting the Plaincoder

(see figure 13)

1. Drill the holes (diameter 8,5mm.) required for mounting the support (drill them according to the hole-pattern in figure 13).
2. Mount both portals of the support keeping in mind the coders position decided upon in 4.2.1.
3. Hang the coder in the mounted support.
4. Adjust the coder to the correct height (see 4.3.1).

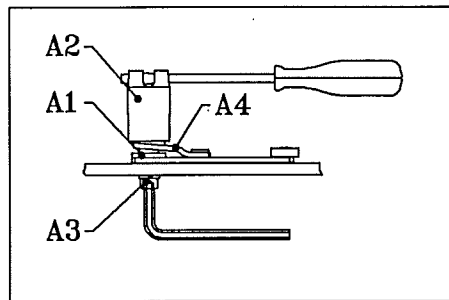
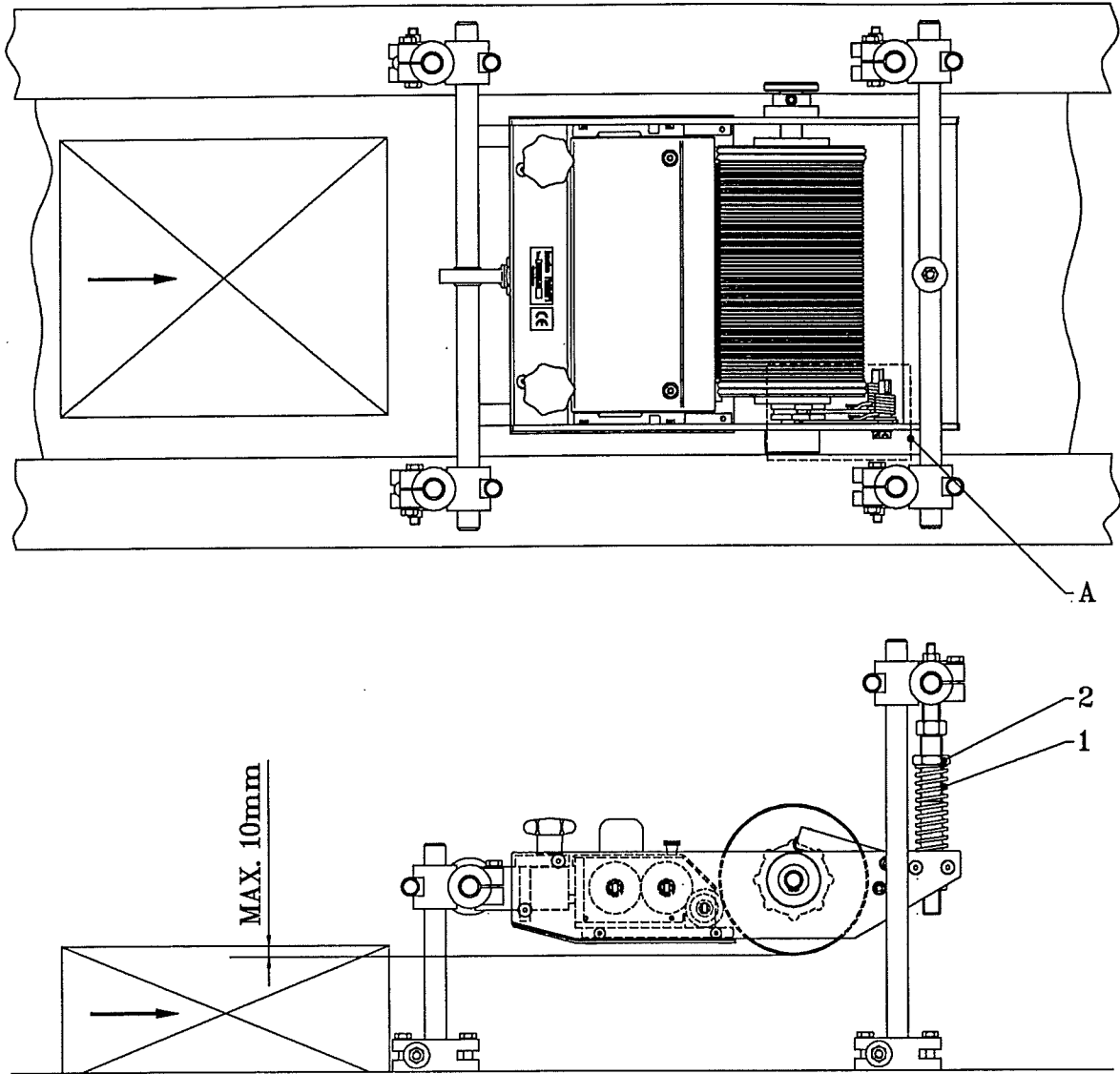

Detail A : The excenter mechanism

Figure 14 : Adjusting the coder

4.3 ADJUSTING THE PLAINCODER

4.3.1 Adjusting the height

(see figure 14)

In order to ensure a correct functioning of the Plaincoder a correct height adjustment is essential. The coder may be 25mm. oblique at the most (the textroll's side may be 25mm. lower than the inkcontainers side).

The coder has been set to the correct height when the lower side of the textroll in released position is situated at maximum 10mm. underneath the surface of the product to be imprinted.

4.3.2 Adjusting the stamping pressure

(see figure 14)

Depending on the products surface's quality as well as the desired printing quality, a higher or a lower stamping pressure is required. The stamping pressure should always be adjusted as low as possible. The force with which the spring (1) presses the coder on the product is to be adjusted with the nut (2) between the spring and the suspension.

4.3.3 Adjusting the excenter mechanism

(see figure 14, detail A)

The excenter springs return the textroll to its zero-position after coding a product. The excenter springs needs to be tensioned as little as possible, in order to enable a smooth rotation of the textroll. The excenter springs can be adjusted independently.

1. Block the axis (A1) with the supplied spanning tools (A2).
2. Turn loose the bolt (A3).
3. Set the spring (A4) to the required tension.
4. Tighten the bolt.

4.4 THE TEXTROLL

Exchanging textrolls is a very fast means of changing printing texts.

4.4.1 Removing the textroll

(see figure 15)

1. Set the inking system (1) into neutral position. To do so turn both buttons (2) of the pressure mechanism halfway around.

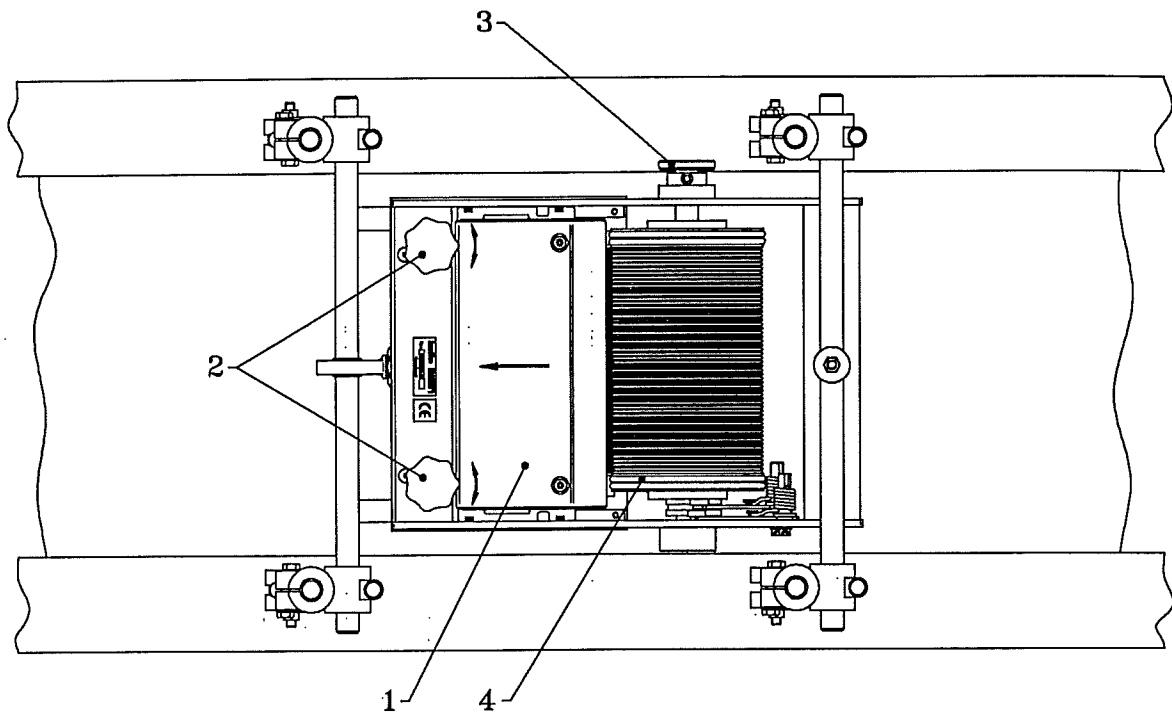

Figure 15 : Removing and placing the textroll

2. Slide the inking system backwards (in the figure to the left).
3. Pull out the lockingdisk (3).
4. Turn around the lockingdisk a quarter turn thus making it block.
5. Remove the textroll (4).

4.4.2 Inserting the textroll

1. Insert the textroll (mind the position of the text!).
2. Turn back the lockingdisk a quarter turn thus de-blocking it.
3. Pressure the inking system by turning both buttons of the pressure mechanism half a turn backwards.

4.4.3 Positioning the text on the product

Changing the position of the textroll regarding the neutral position enables you to change the position of the print on the product.

4.5 INSERTING AND REMOVING TYPE

The textroll is covered with a rubber baseplate which has a special profile. The type has the same profile on the reverse side. With one simple pressing movement the type is attached to the textroll.

TIP:

Moisten the side with the profile with water in order to facilitate attaching larger type.

In order to remove a type, simply pull it off of the textroll.

4.6 INK AND SOLVENTS

WARNING:

The ink and solvents that are used may be a hazard to the health when used incorrectly.

For a correct use and possible precautions see the indications on the packaging. Data-sheets with the types of ink and solvents are at request available at B.V. Korthofah.

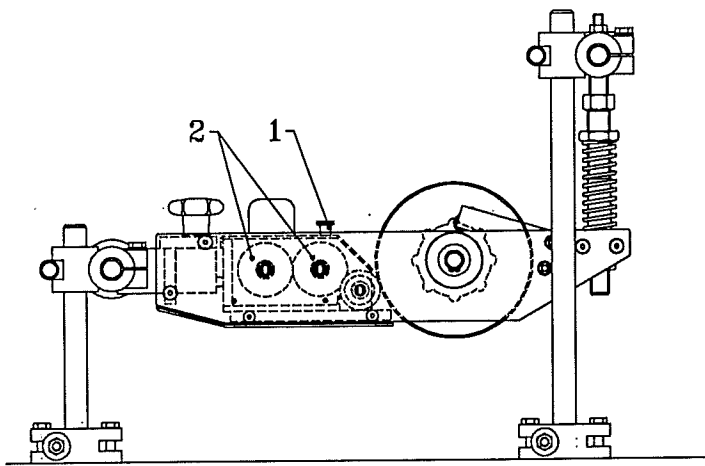

A

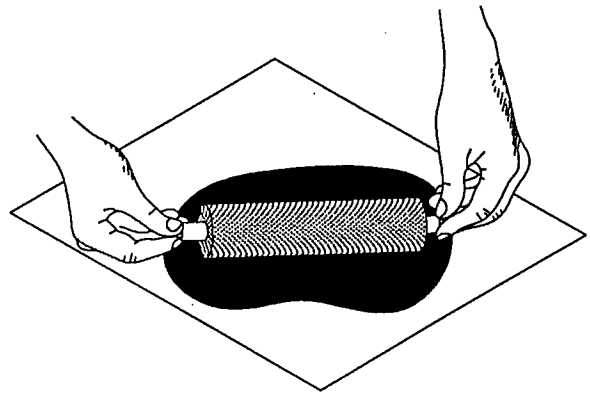

B

Figure 16 : Inking the ink container

WARNING:

With the Kortho Coders only specially designed Kortho inks are to be used.

NOTICE:

Solvent is only to be used for the cleaning of the Kortho Coder and never for diluting ink!

Depending on the application this may be a quick drying ink (for non-porous surfaces) or a slow drying ink (for porous surfaces).

A special solvent is available for each sort of ink. Check with the ink schedule (see appendix A) to decide on which solvent to use.

4.7 THE INKING SYSTEM

WARNING:

Be careful not to overink!

Use only the recommended kind of ink for coding (see the ink schedule in appendix A).

4.7.1 Inking the coder when putting in use (see figure 16)

1. Take valve (1) off of the inking system.
2. Remove the inkcontainers (2) from the inking system.
3. Impregnate the inkcontainers with ink (see figure 16B)
4. Return the inkcontainers into the inking system.
5. Replace the valve on the inking system.

4.7.2 Re-inking the inkcontainers

1. Take the valve off of the inking system.
2. By means of the ink bottle apply the correct amount of ink to the ink container.
3. Replace the valve on the inking system.

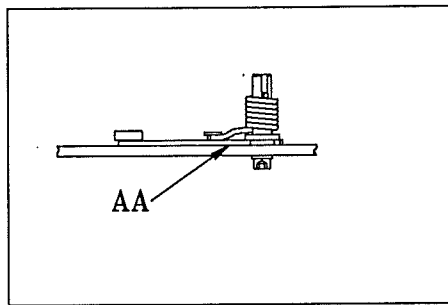
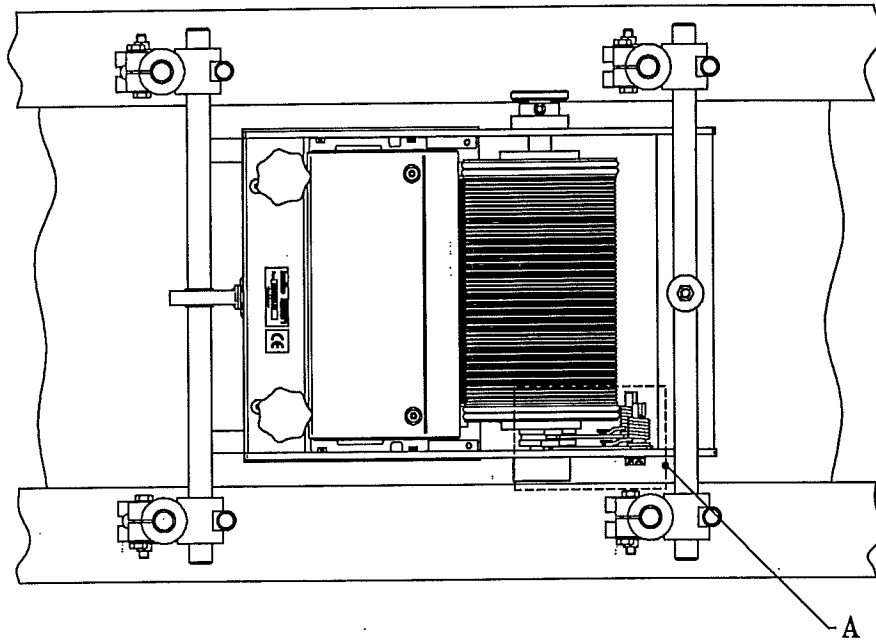

Detail A : The excenter mechanism

Figure 17 : Greasing the coder

4.8 PREVENTIVE MAINTENANCE

The following maintenance periods have been set for a normal use of the coding equipment. When under more extreme operating conditions it may prove necessary to modify these according to ones own experience.

4.8.1 Cleaning

Clean all parts of the coder regularly (at least once a week). Doing so use only the right kind of solvent (see ink schedule in appendix A).

4.8.2 Checking the running bands

Prevent wear of the type by regularly (at each maintenance service) checking the textroll's rubber running bands for possible wear and intactness. If necessary replace them.

4.8.3 Checking the inking system

Regularly check the inking system's rolls on intactness. This check must be performed before each inking and/or with each replacement of the inkroll.

4.8.4 Greasing the excenter mechanism

(see figure 17)

The excenter mechanism is greased by putting a drop of oil on the indicated point (AA in detail A).

5	THE INKPUMP	
5.1	GENERAL INTRODUCTION	39
5.2	MOUNTING THE INKPUMP	39
5.3	ADJUSTING THE INKPUMP	39
5.4	PREVENTIVE MAINTENANCE	41
	5.4.1 Cleaning of the inkpump	41
	5.4.2 Checking the inkpipes	41
	5.4.3 Replacing the inkpipes	41

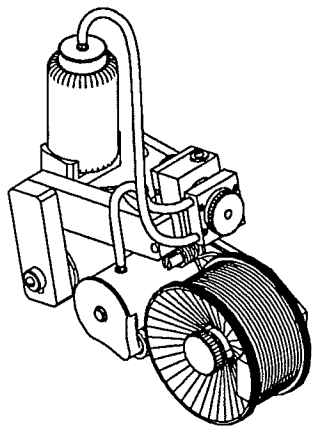

A

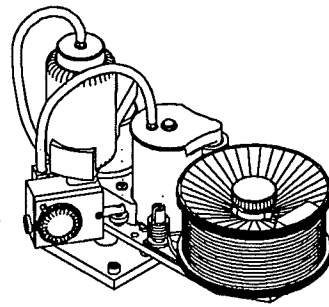

B

Figure 18 : Mounting possibilities for the inkpump

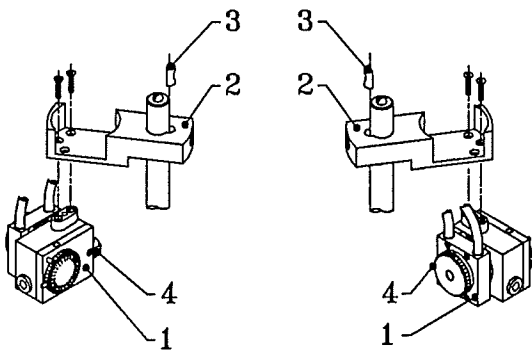

IS-L

IS-R

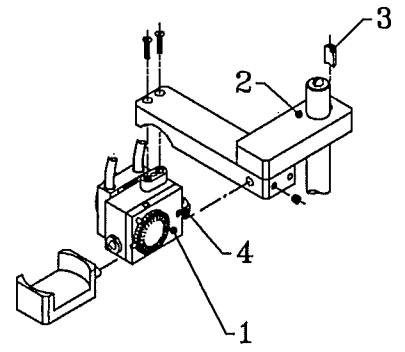
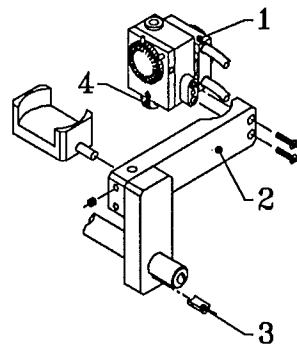

Figure 19 : Mounting the inkpump

5 THE INKPUMP

5.1 GENERAL INTRODUCTION

The inkpump is an additional option for the coders with exchangeable textrolls, model IS and the Plaincoder model ISP. The function of the inkpump is to ensure a continuous and automatic ink supply to the inkingroll.

5.2 MOUNTING THE INKPUMP

(figures 18 and 19)

Consult with figure 18 for a survey of Mounting possibilities. Pay attention to the free space around the coder, and be sure to place it so it won't be possible to get caught between the coder and its surrounding (NEN-EN 294 and 349). If necessary relocate the coder.

For mounting the inkpump on the coder various supports are supplied that may be mounted on the indicated position (consult the dimensional diagram in appendix D).

1. Mount the inkpump (1) in the desired position on the inkpump-container (2) (see figure 19).
2. Place the inkpump-container on the support.
3. Apply the pressure plate (3).
4. Mount the container in the right position. When a product passes by the coder must press the pressure pin (4) of the inkpump 5 to 8mm. inwards.
5. Fill the ink container of the inkpump maximum 2/3 with the right Kortho ink (see ink schedule in appendix A).

5.3 ADJUSTING THE INKPUMP

(see figure 20)

WARNING:

Be careful not to overink!

The quantity of the ink supply is adjusted by turning the adjustment button (1) on the inkpump.

Set the ring to position 0 (= no supply).

Carefully rotate the ring little by little until the desired position has been obtained.

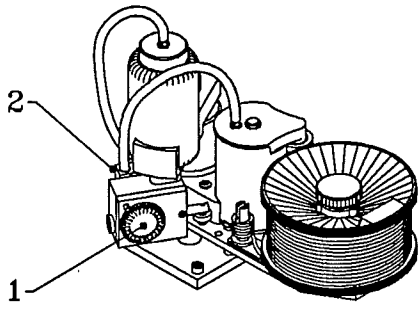
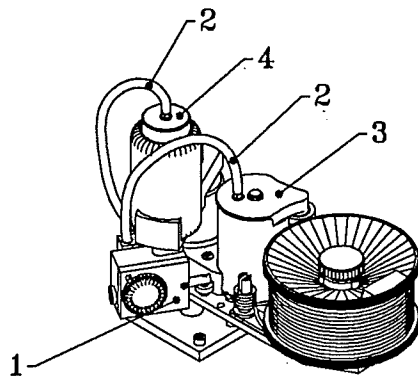
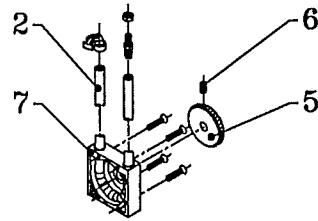

Figure 20 : Adjusting the inkpump



A



B

Figure 21 : Replacing the inkpipe

5.4 PREVENTIVE MAINTENANCE

5.4.1 Cleaning the inkpump

(see figure 20)

Flush the inkpump through regularly in order to prevent obstructions (about four times a year). Use only the correct solvent to do this (see appendix A).

By manually turning the handwheel (2) it can be easily flushed through.

5.4.2 Checking the inkpipes

Regularly (once a year) replace the inkpipe, in order to prevent leakage and to guarantee a correct functioning of the inkpump.

5.4.3 Replacing the inkpipe

(see figure 21)

1. Demount the inkpump (1).
2. Release the inkpipe (2) from the inking system (3) beware for possible drops of ink.
3. Release the inkpipe from the container (4). Also beware for ink drops.
4. Demount the handwheel (5) by releasing the screw (6).
5. Demount the cover (7).
6. Remove the inkpipe.
7. Clean all parts with the correct kind of solvent (see appendix A).
8. Lightly grease the part of the ink tube inside the cover.
9. Insert the new inkpipe.
10. Mount the inkpump by performing the previously mentioned actions 1 to 5 in reversed order.

6	KORTHO HIGHSPEED CODER, MODEL HS AND HSD	
6.1	GENERAL INTRODUCTION	45
6.2	MOUNTING INSTRUCTIONS	45
6.2.1	Positioning the HS coder	45
6.2.2	Mounting the HS coder	45
6.3	ADJUSTING THE HIGHSPEED CODER	47
6.3.1	Adjusting the torque-spring	47
6.4	THE TEXTROLL	47
6.4.1	Adjusting the textroll	47
6.4.2	Exchanging textrolls	47
6.5	INSERTING AND REMOVING TYPE	49
6.6	THE INKING SYSTEM	49
6.6.1	Mounting the inking system	49
6.6.2	Refilling the inking system	49
6.7	INK AND SOLVENTS	49
6.8	PREVENTIVE MAINTENANCE	51
6.8.1	Cleaning	51
6.8.2	Checking the running bands	51
6.8.3	Checking the inking system	51

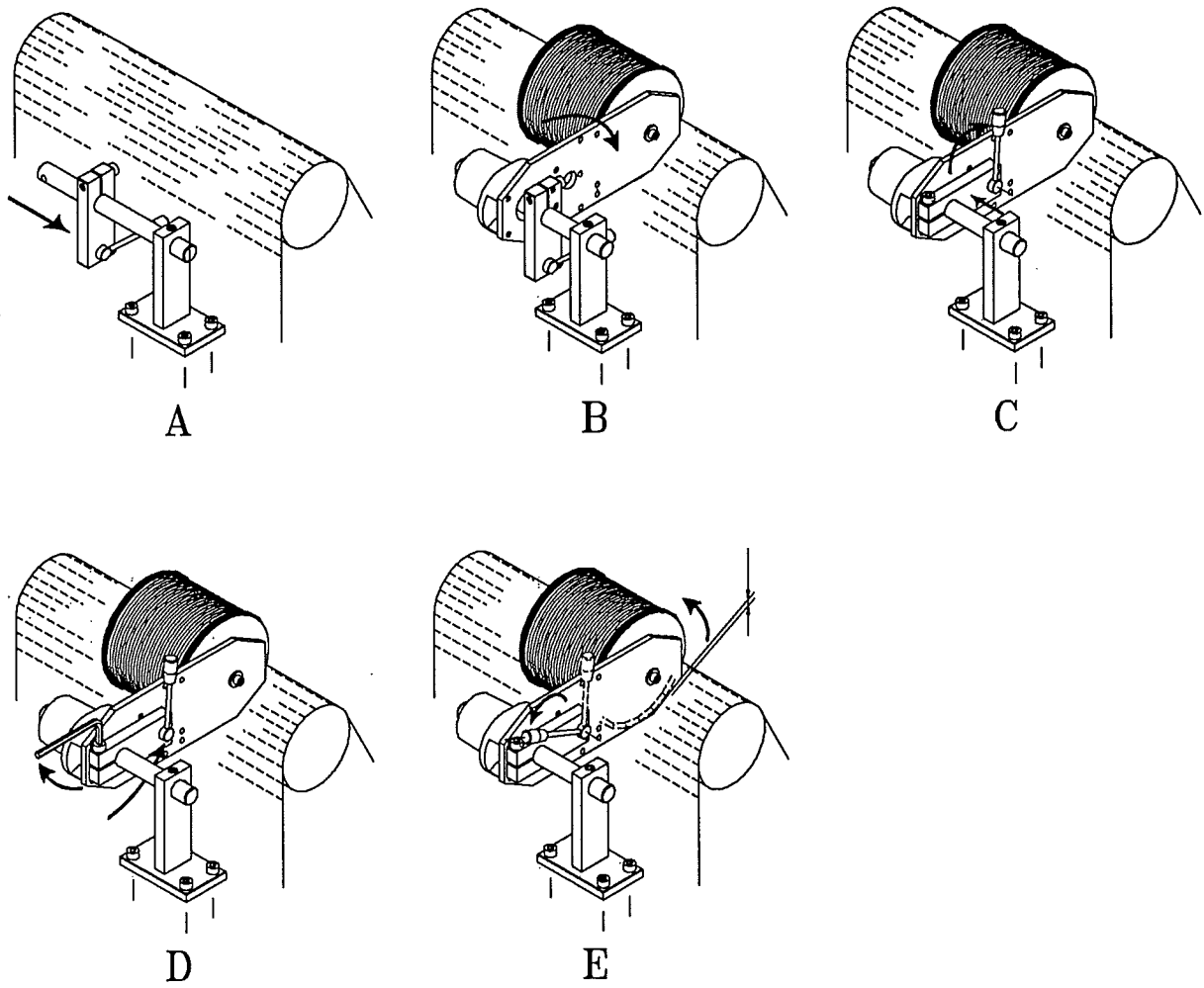

Figure 22 : Mounting the coder

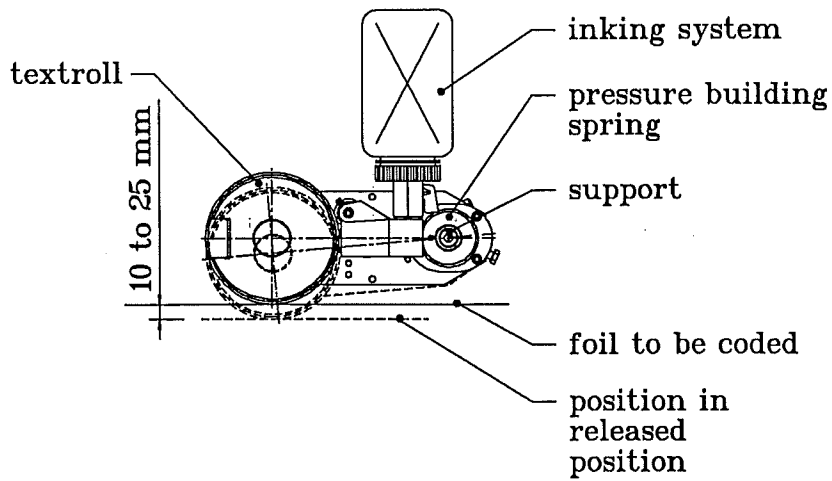

Figure 23 : Position of the coder

6 KORTHO HIGHSPEED CODER, MODELS HS AND HSD

6.1 GENERAL INTRODUCTION

(see figure 23)

The Kortho Highspeed coder has been developed for continuous highspeed printing (150m./min.) on continuous products.

The text for the print is inserted on a replaceable textroll by means of rubber type. The system is being inked with liquid ink. According to the preferred position one may choose between model HS and HSD.

6.2 MOUNTING INSTRUCTIONS

Consult appendix C for a survey of the mounting possibilities. When mounting pay special attention to the free space around the coder, and place it so it is impossible to get caught between the coder and its surroundings (NEN-EN 294 and 349).

6.2.1 Positioning the HS coder

The transportation direction of the products decides the position in which the coder has to be mounted. In the figure in appendix C is indicated how to mount the coder if the product passes by in the direction of the arrow. Once the correct positioning has been established, the coder may be mounted.

6.2.2 Mounting the HS coder

(see figures 22 and 23)

1. Drill the mounting-holes for the support at the desired place on your machine or conveyor belt (diameter 6,5mm. or M6). Drill the holes at centres of 40 x 80mm.
2. Mount the support with bolts M6 (4x).
3. Slide the excenter mechanism on the support (see figure 22A).
4. Attach the coder in the desired position to the support (see figure 22B). The coder should be 10 to 25 mm. into the product's path.
5. Move the excenter mechanism against the coder (see figure 22C).
6. Place the handle in the position as shown.
7. Turn the excenter mechanism in the direction of the arrow against the hit (see figure 22D).
8. Fix the excenter mechanism by tightening the bolt.
9. Elevate the textroll from the material by turning the excenter mechanism's handle in the indicated direction (see figure 22E).

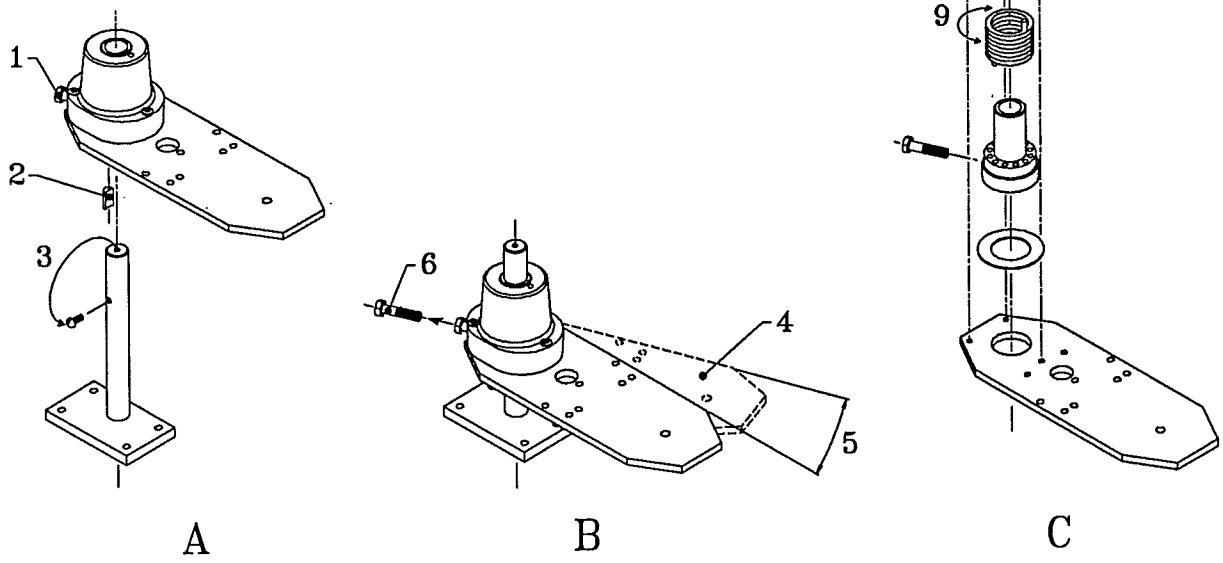

Figure 24 : Adjusting the torque-spring

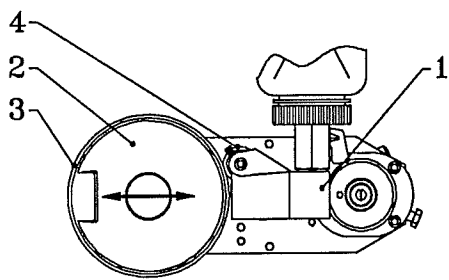

Figure 25 : Adjusting the textroll

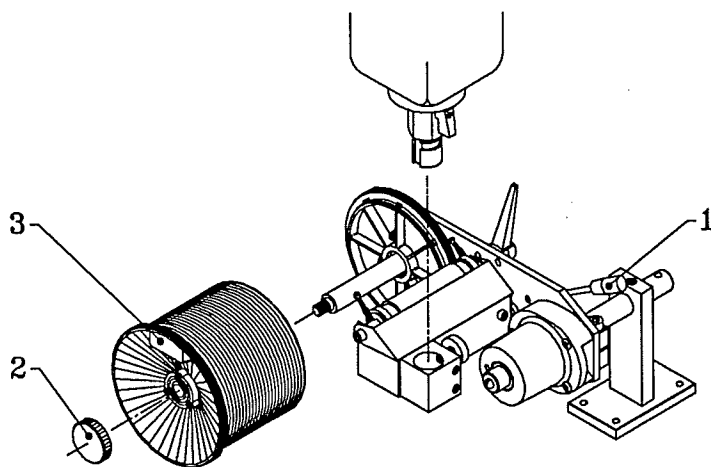

Figure 26 : Exchanging textrolls

6.3 ADJUSTING THE HIGHSPEED CODER

6.3.1 Adjusting the torque-spring

(see figure 24)

1. Remove the coder from the support by loosening the bolt (1).
2. Remove the pressure plate (2).
3. Turn loose the screw (3) at the upper side of the support and place it inside the hole at the side of the support.
4. Place the coder on the support, in such a way that the screw head will fit into the opening of the pressure plate.
5. Tension the torque-spring by twisting the coder (4+5).
6. Remove the bolt (6).
7. Take the pressure off the torque-spring.
8. Remove the 4 bolts (7)
9. Remove the cover (8).
10. Place the torque-spring in the desired position (9).
11. Mount the coder in reversed order.

6.4 THE TEXTROLL

6.4.1 Adjusting the textroll

(see figure 25)

Manually check (before using!) whether the inking system's (1) rolls are rotating smoothly. If this is not the case the textroll's position needs adjusting. The textroll (2) has to be mounted so the running bands (3) precisely touch the ink distributor-roll (4). In that case the ink distributor-roll will smoothly rotate together with the textroll.

6.4.2 Exchanging textrolls

(see figure 26)

Exchanging textrolls is a very fast means of changing the printing text.

1. Set the coder into the neutral position. Turn the handle (1) to free the coder from the product.
2. Screw the bolt (2) off of the textroll.
3. Remove the textroll (3) from the coder.
4. Place the new textroll.
5. return the bolt to its position.
6. Reset the handle into its original position.

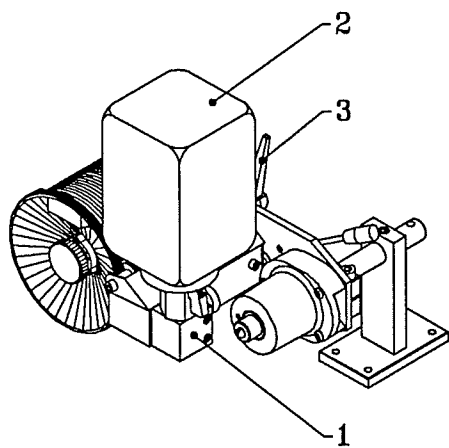

Figure 27 : Mounting the inking system

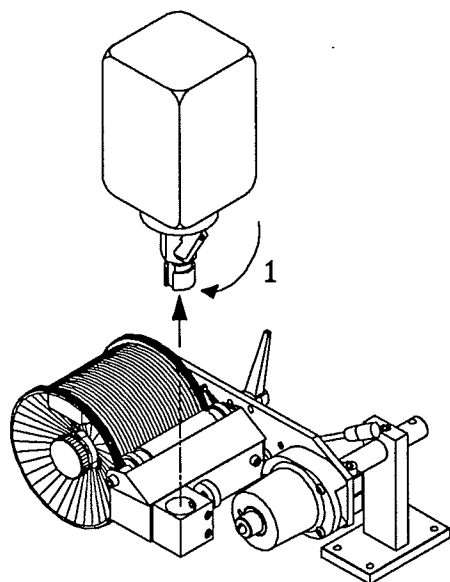

Figure 28 : Filling the inking system

6.5 INSERTING AND REMOVING TYPE

The textroll is covered with a rubber baseplate which has a special profile. The type has the same profile on the reverse side. With one simple pressing movement the type is attached to the textroll.

TIP:

Moisten the side with the profile with water in order to facilitate attaching larger type.

In order to remove a type, simply pull it off of the textroll.

6.6 THE INKING SYSTEM

6.6.1 Mounting the inking system

(see figure 27)

The inking system (1) should always be in horizontal position (see appendix C). The ink container (2) should point vertically upwards.

The inking systems position may be adjusted after releasing the handle (3).

6.6.2 Refilling the inking system

(see figure 28)

1. Close the tab (1) on the ink container.
2. Release the ink container with the button (2).
3. Take the ink container off of the inking system.
4. Fill the ink container.
5. Close the tab on the ink container, after filling.
6. Place the ink container on the inking system.
7. Lock the ink container with the button.
8. Open the ink container's tab.

6.7 INK AND SOLVENTS

WARNING:

The ink and solvents that are used may be a hazard to the health when used incorrectly.

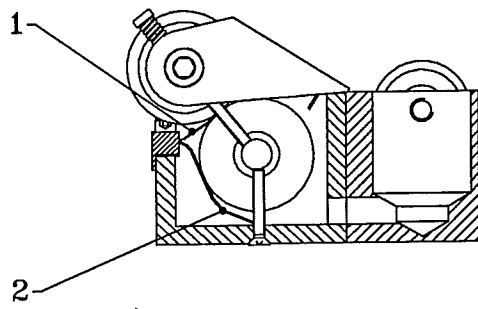

Figure 29 : Position of the ink scrapers

For a correct use and possible precautions see the indications on the packaging. Data-sheets with the types of ink and solvents are at request available at B.V. Korthofah.

WARNING:

With the Kortho Coders only specially designed Kortho inks are to be used.

NOTICE:

Solvent is only to be used for the cleaning of the Kortho Coder and never for diluting ink!

A different kind of solvent is available for each type of ink. Consult the ink schedule (see appendix A) in order to decide which kind of solvent to use.

6.8 PREVENTIVE MAINTENANCE

The following maintenance periods have been set for a normal use of the coding equipment. When under more extreme operating conditions it may prove necessary to modify these according to ones own experience.

6.8.1 Cleaning

Clean all parts of the coder regularly (at least once a week). Doing so use only the right kind of solvent (see appendix A).

6.8.2 Checking the running bands (see figure 29)

Prevent wear of the type by regularly (at each maintenance service) checking the textroll's rubber running bands for possible wear and intactness. If necessary replace them.

6.8.3 Checking the inking system

Regularly (at every maintenance service) check the inking system's rolls on intactness.

7	KORTHO HANDCODER WITH EXCHANGEABLE TEXTROLL, MODELS IS AND KL	
7.1	GENERAL INTRODUCTION	55
7.2	ADJUSTING THE EXCENTER MECHANISM	
7.3	THE TEXTROLL	55
	7.3.1 Adjusting the textroll	55
	7.3.2 Positioning the text on the product	55
	7.3.3 Exchanging textrolls	57
7.4	INSERTING AND REMOVING TYPE	57
7.5	INK AND SOLVENTS	57
	7.5.1 The inking system with liquid ink	59
	7.5.1.1 Inking the ink container when putting into use	59
	7.5.1.2 Re-inking the ink container	59
	7.5.2 The Kortho Lon inking system	59
7.6	PREVENTIVE MAINTENANCE	61
	7.6.1 Cleaning	61
	7.6.2 Checking the running bands	61
	7.6.3 Checking the inking system	61
	7.6.4 Greasing the coder	61

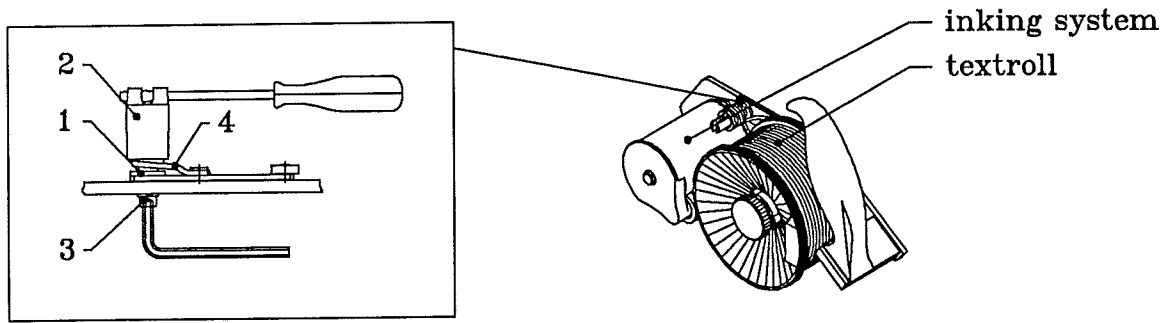

Figure 30 : Adjusting the excenter mechanism

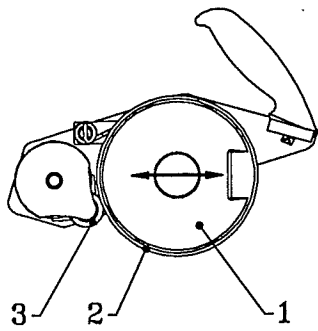

Figure 31 : Adjusting the textroll

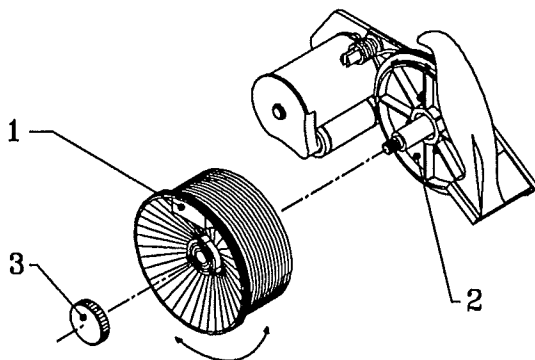

Figure 32 : Positioning the text

7 KORTHO HANDCODER WITH EXCHANGEABLE TEXTROLL, MODELS IS AND KL

7.1 GENERAL INTRODUCTION

(see figure 30)

The Kortho handcoder has been developed for manually coding products. In order to code a product you simply move the handcoder over the product.

The text for the print is inserted on a replaceable textroll by means of rubber type. The system is being inked with an ink cartridge (model KLM) or with liquid ink (model ISM).

7.2 ADJUSTING THE EXCENTER MECHANISM

(see figure 30)

The excenter springs return the textroll to its zero-position after coding a product. The excenter springs needs to be tensioned as little as possible, in order to enable a smooth rotation of the textroll. The excenter springs can be adjusted independently.

1. Lock the axis (A1) with the supplied spanning tools (A2).
2. Loosen the bolt (A3).
3. Set the spring (A4) to the required tension.
4. Tighten the bolt.

7.3 THE TEXTROLL

7.3.1 Adjusting the textroll

(see figure 31)

Manually check (before using!) whether the inking system's rolls are rotating smoothly. If this is not the case the textroll's position needs adjusting. The textroll (1) has to be mounted so the running bands (2) precisely touch the ink distributor-roll (3). In that case the ink distributor-roll will smoothly rotate together with the textroll.

7.3.2 Positioning the text on the product

(see figure 32)

Changing the textroll's (1) position on the lower disk (2) allows you to change the position of the print on the product. The textroll is equipped with notches, into which the ridges on the lower disk fit. With these the textroll can be rotated and fixed in steps of 45 degrees.

1. Loosen the bolt (3).
2. Rotate the textroll into a desired position.
3. Tighten the bolt.

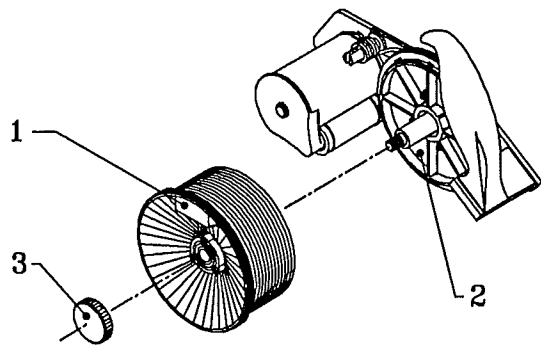

Figure 33 : Exchanging textrolls

7.3.3 Exchanging textrolls (see figure 33)

Exchanging textrolls is a very fast means of changing the printing text.

1. Loosen the bolt.
2. Take the textroll off of the coder.
3. Place the new textroll (pay attention to the position of the text!).
4. Tighten the bolt.

7.4 INSERTING AND REMOVING TYPE

The textroll is covered with a rubber baseplate which has a special profile. The type has the same profile on the reverse side. With one simple pressing movement the type is attached to the textroll.

TIP:

Moisten the side with the profile with water in order to facilitate attaching larger type.

In order to remove a type, simply pull it off of the textroll.

7.5 INK AND SOLVENTS

WARNING:

The ink and solvents that are used may be a hazard to the health when used incorrectly.

For a correct use and possible precautions see the indications on the packaging. Data-sheets with the types of ink and solvents are at request available at B.V. Korthofah.

WARNING:

With the Kortho Coders only specially designed Kortho inks are to be used.

NOTICE:

Solvent is only to be used for the cleaning of the Kortho Coder and never for diluting ink!

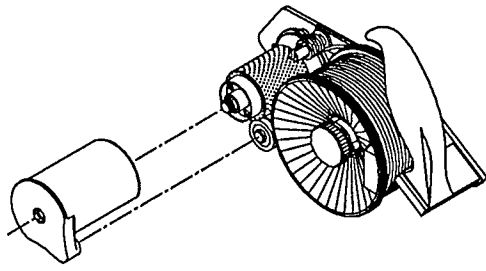

A

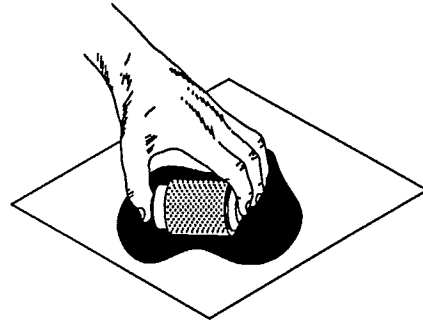

B

Figure 34 : Inking the ink container

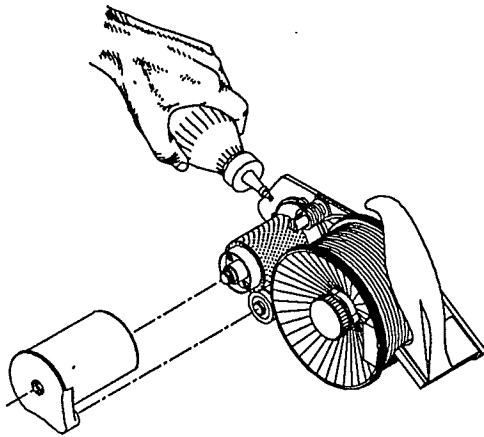

Figure 35 : Re-inking the ink container

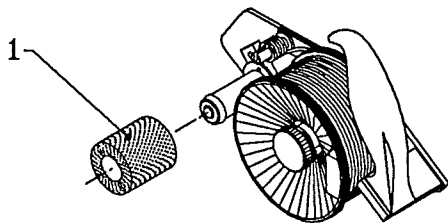

Figure 36 : Kortho-lon inking system

Depending on the application this may be a quick drying ink (for non-porous surfaces) or a slow drying ink (for porous surfaces).

A special solvent is available for each sort of ink. Check with the ink schedule (see appendix A) to decide on which solvent to use.

If your coder is equipped with the Kortho Lon inking system (model KLM), read on with 7.5.2.

7.5.1 The inking system with liquid ink

WARNING:

Be careful not to overink!

7.5.1.1 Inking the ink container when putting in use (see figure 34)

1. Remove the inking cover (1)
2. Remove the ink container (2) from the coder.
3. Impregnate the ink container with ink (see figure 34B)
4. Return the ink container into the coder.

7.5.1.2 Re-inking the ink container (see figure 35)

In order to re-ink the ink container remove the inking cover and directly apply the correct amount of ink onto the ink container.

7.5.2 The Kortho Lon inking system (see figure 36)

The Kortho Lon inking system uses an impregnated ink cartridge (1). This cartridge can **not be refilled** but needs to be duly replaced with a new one. After its use the used cartridge may be disposed of as small chemical waste.

TIP:

While placing a new ink cartridge the textroll may be marked. To prevent this insert while replacing the ink cartridge a small piece of plastic foil between the textroll and the new cartridge.

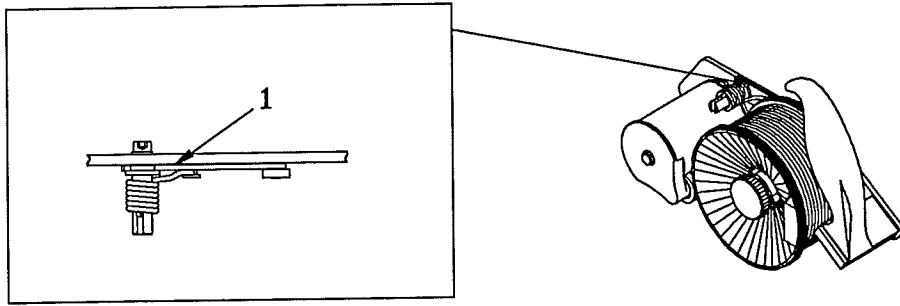

Figure 37 : Greasing the coder

7.6 PREVENTIVE MAINTENANCE

The following maintenance periods have been set for a normal use of the coding equipment. When under more extreme operating conditions it may prove necessary to modify these according to ones own experience.

7.6.1 Cleaning

Clean all parts of the coder regularly (at least once a week). Doing so use only the right kind of solvent (see appendix A).

7.6.2 Checking the running bands

Prevent wear of the type by regularly (at each maintenance service) checking the textroll's rubber running bands for possible wear and intactness. If necessary replace them.

7.6.3 Checking the inking system

Regularly (at each maintenance service) check the inking system's rolls for intactness.

7.6.4 Greasing the coder (see figure 37)

Regularly (at each maintenance service) grease the indicated point with a drop of oil.

8	HANDCODER, MODEL ERP	
8.1	GENERAL INTRODUCTION	
8.2	INSERTING AND REMOVING TYPE	65
8.3	THE KORTHO-LON INKING SYSTEM	65
8.4	PREVENTIVE MAINTENANCE	67
	8.4.1 Cleaning	67
	8.4.2 Checking the running bands	67

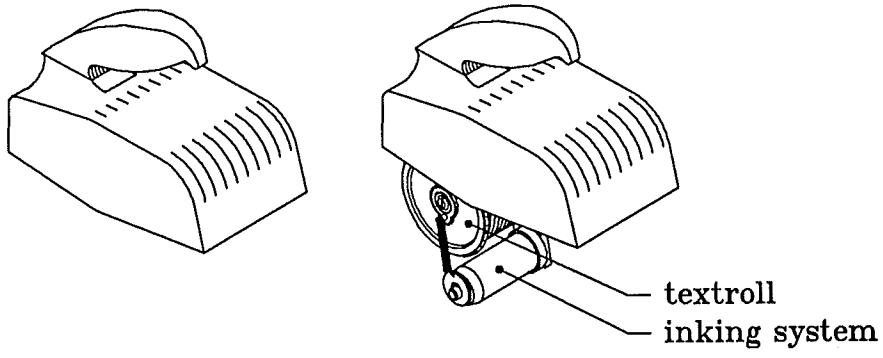

Figure 38 : Handcoder model ERP

8 HANDCODER, MODEL ERP

8.1 GENERAL INTRODUCTION

(see figure 38)

The Kortho handcoder (model ERP) has been developed for manually coding products. In order to code a product you simply move the handcoder over the product. The text for the print is inserted on a textroll by means of type. The system being inked through an ink cartridge.

8.2 INSERTING AND REMOVING TYPE

The textroll is covered with a rubber baseplate which has a special profile. The type has the same profile on the reverse side. With one simple pressing movement the type is attached to the textroll.

TIP:

Moisten the side with the profile with water in order to facilitate attaching larger type.

In order to remove a type, simply pull it off of the textroll.

8.3 THE KORTHO-LON INKING SYSTEM

WARNING:

The ink and solvents that are used may be a hazard to the health when used incorrectly.

For a correct use and possible precautions see the indications on the packaging. Data-sheets with the types of ink and solvents are at request available at B.V. Korthofah.

WARNING:

With the Kortho Handcoder (model ERP) only special designed Kortho Lon ink cartridges may be used.

The Kortho Lon inking system uses an impregnated ink cartridge. This cartridge can **not** be refilled but needs to be duly replaced with a new one. After its use the used cartridge may be disposed of as small chemical waste.

TIP:

While placing a new ink cartridge the textroll may be marked. To prevent this insert while replacing the ink cartridge a small piece of plastic foil between the textroll and the new cartridge.

8.4 PREVENTIVE MAINTENANCE

The following maintenance periods have been set for a normal use of the coding equipment. When under more extreme operating conditions it may prove necessary to modify these according to ones own experience.

8.4.1 Cleaning

Clean all parts of the coder regularly (at least once a week). Doing so use only the right kind of solvent (see appendix A).

8.4.2 Checking the running bands

Prevent wear of the type by regularly (at each maintenance service) checking the textroll's rubber running bands for possible wear and intactness. If necessary replace them.

Appendix A

Ink schedule

TYPE OF INK:	K4	K6	K7	K8	K9
DRYING PERIOD:					
porous	1-2 s.	5-15 s.	15-20 s.	2-3 s.	5-10s.
non-porous	2-3 s.	not appl.	2-5 min.	8-10 min.	not appl.
COLORS:					
black	X	X	X	X	X
blue	X	X	X	X	X
red	X	X	X	X	X
green	X	X	X	X	X
white			X		
yellow					X
silver					X
SOLVENT:					
K1		X	X	X	
K9					X

K4 Very fast drying ink; specially designed for the HS-coder.

K6 Light-transparent ink, universally applicable on porous material.

K7 Coating ink; doesn't run (so applicable on e.g. carpets and tin).

K8 Coating ink with good results on synthetic material and on tin.

K9 Very long shelf life in ink-containers; first choice for application with Kortho coders.

Solvent 1 For K6, K7 and K8

Solvent 9 For K9

Appendix B

Technical details

Type of coder	text-height (mm)	diameter textroll (mm)	max. print length* (mm)	exchangeable roll	inking-system**	Weight (kg)
standard						
25/140	23	140	315/440	yes	IS/KL	2,6
55/140	53	140	315/440	yes	IS/KL	2,8
100/140	98	140	315/440	yes	IS/KL	3,0
25/200	23	200	450/630	yes	IS/KL	4,8
55/200	53	200	450/630	yes	IS/KL	5,0
plain						
200/140H	198	140	315/440	yes	IS	14,5
high speed						
HS 100/140	80	140	---/440	yes	IS	3,3
HSD 100/140	80	140	---/440	yes	IS	3,5
hand						
ERP 50/76	48	76	170/238	yes	KL	0,5
55/140	53	140	315/440	yes	IS/KL	1,3
100/140	98	140	315/440	yes	IS/KL	1,5

*) Print length with coding positioned per object or in continuous printing on strips per rotation.

**) IS, refillable ink container system, respectively KL, Kortho Lon system with impregnated inkrolls.

Appendix C

Survey mounting possibilities high-speed coders

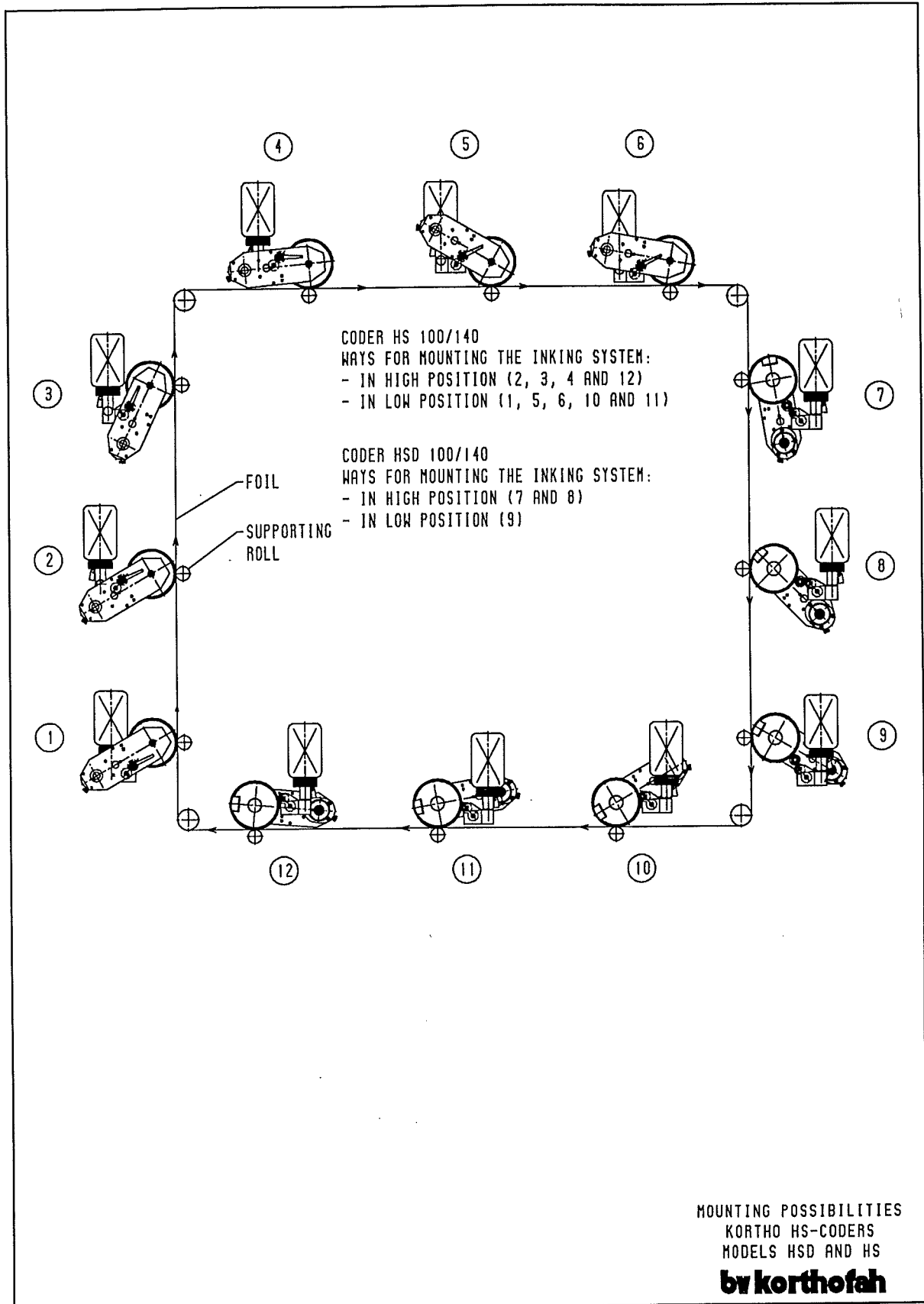

Appendix D

Dimensional diagrams

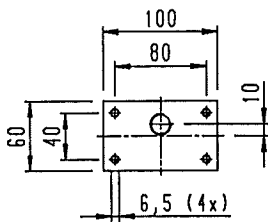
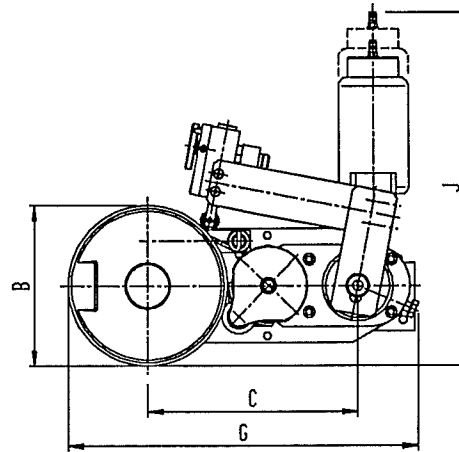
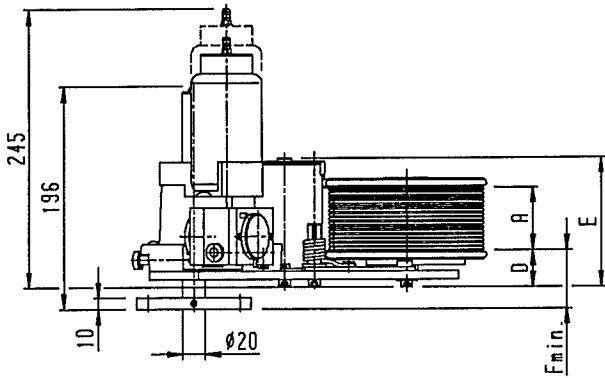
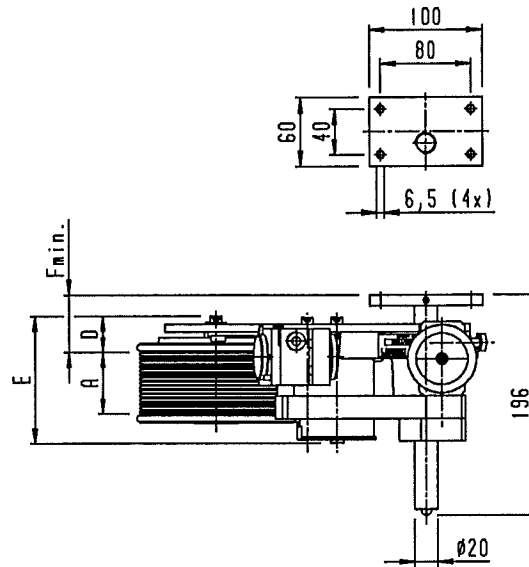
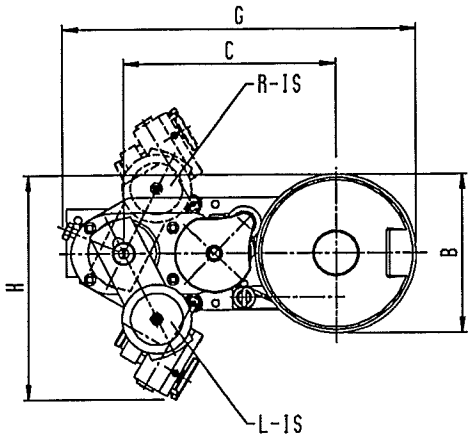

HORIZONTAL SETTING

VERTICAL SETTING

DIMENSIONAL DIAGRAM
KORTHO-CODERS
MODEL IS

by korthofah

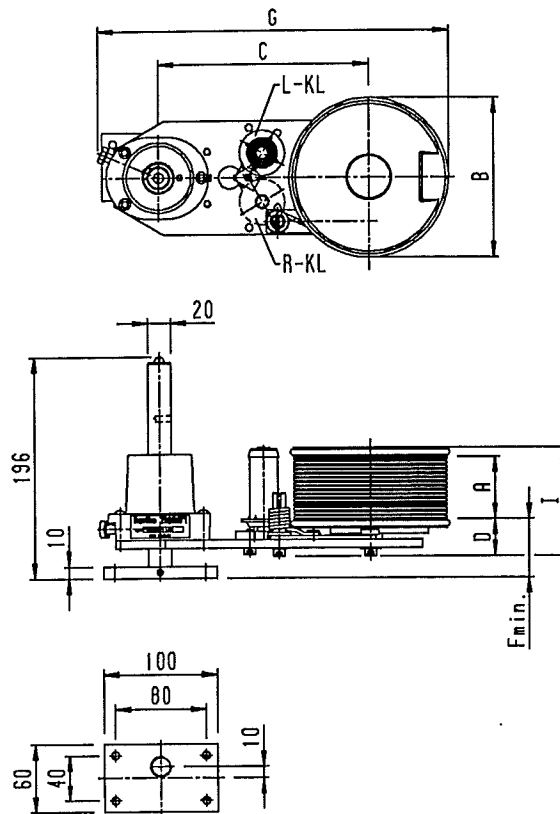

HORIZONTAL/VERTICAL SETTING

MODEL	L-IS	R-IS	L-KL	R-KL	A	B	C	D	E	Fmin.	G	H	I	J
25/140	900938	900941	900995	901008	25	140	186	33	91	36	310	207	66	310
55/140	900954	900967	901011	901024	55	140	186	33	114	36	310	207	96	310
100/140	900979	900982	901037	901049	100	140	186	33	159	36	310	207	141	310
25/200	901094	901107	901135	901148	25	200	217	35	93	36	373	237	93	340
55/200	901119	901122	901151	901164	55	200	217	35	122	36	373	237	122	340

DIMENSIONAL DIAGRAM
KORTHO-CODER
MODEL KL

by korthofah

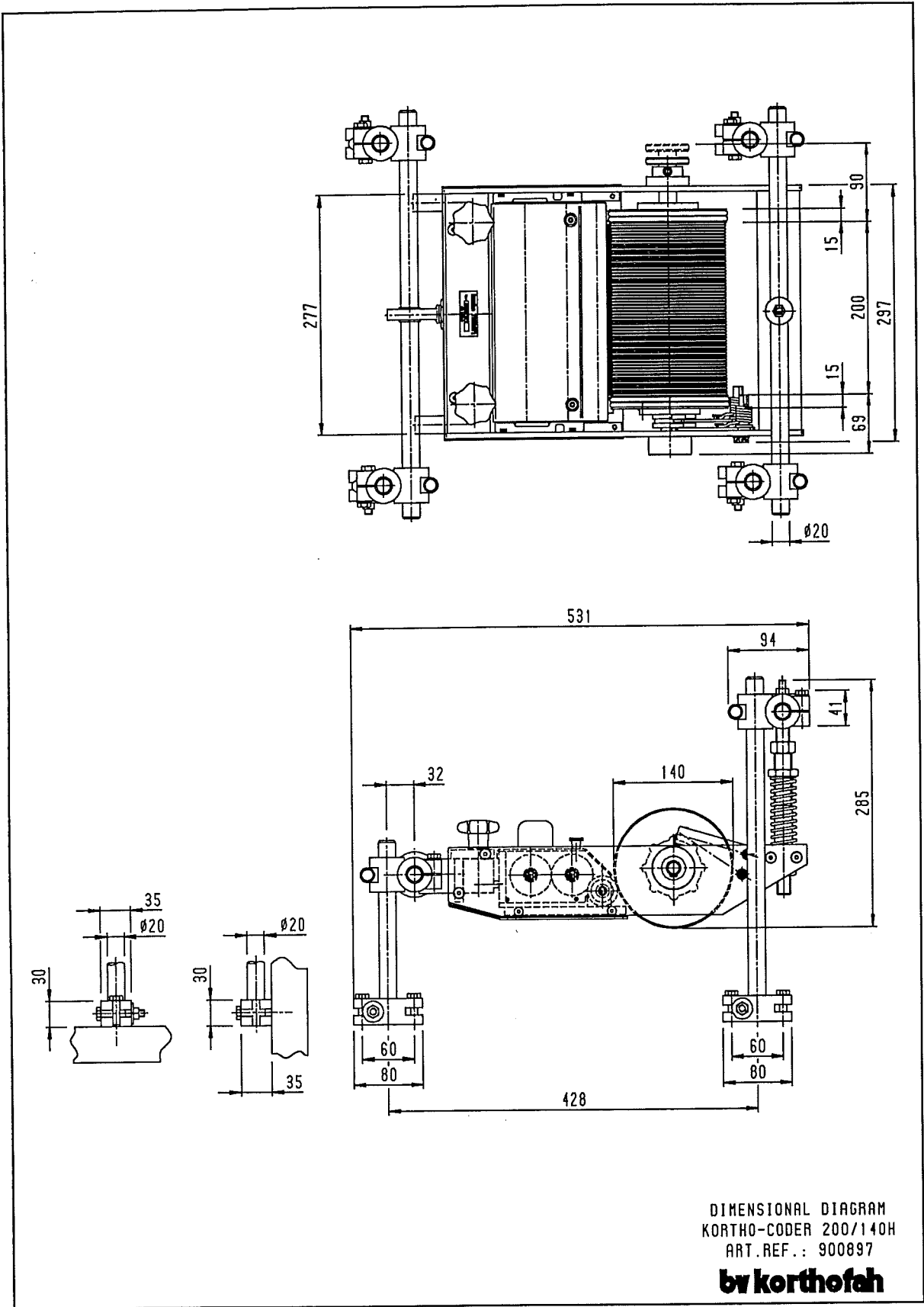

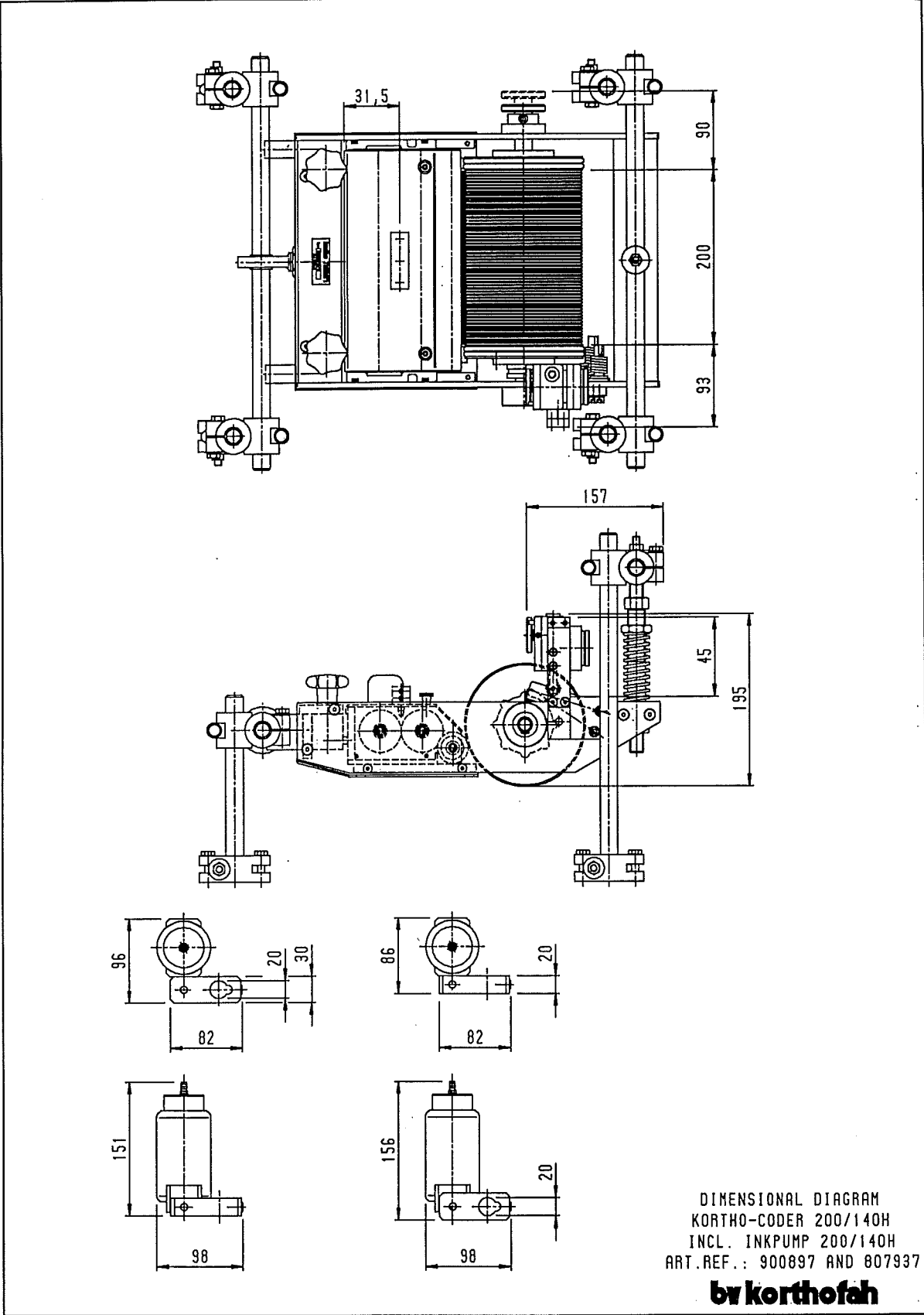

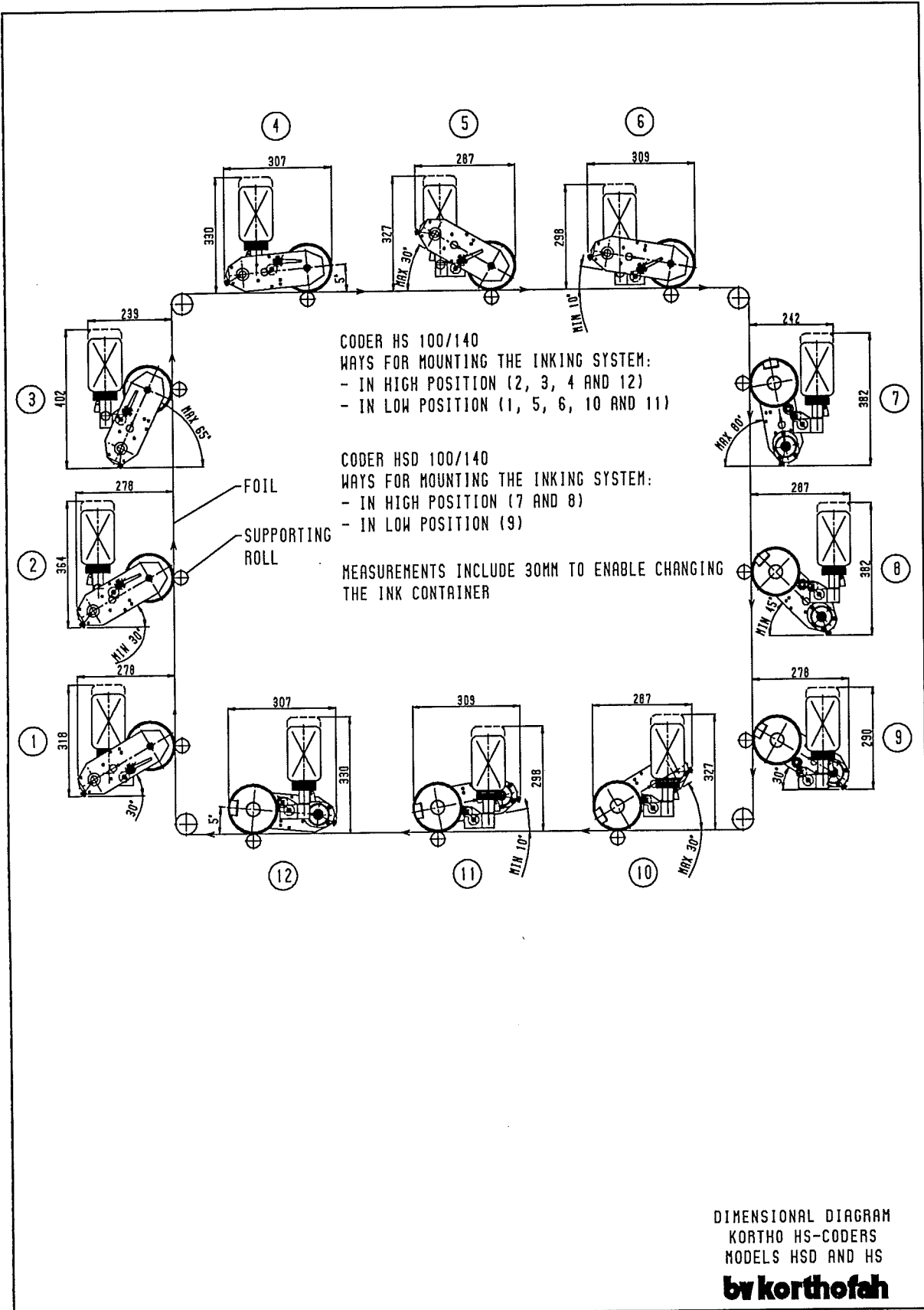

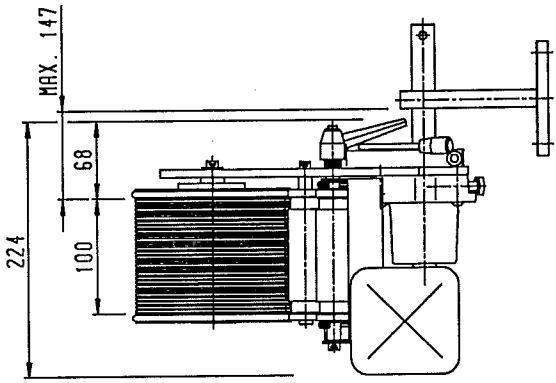
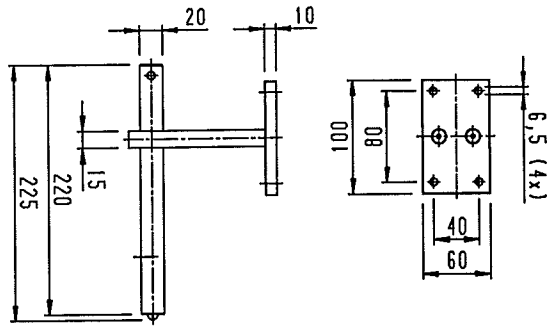

VIEU P

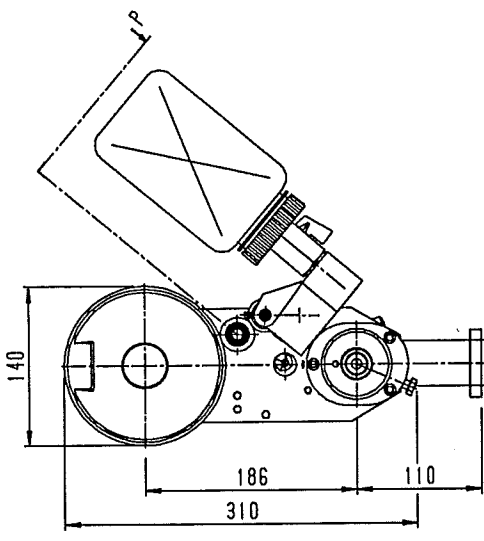
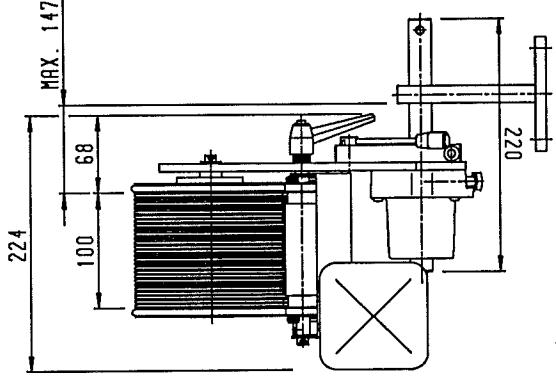

KORTHO-CODER HSD 100/140
ART. REF.: 901288

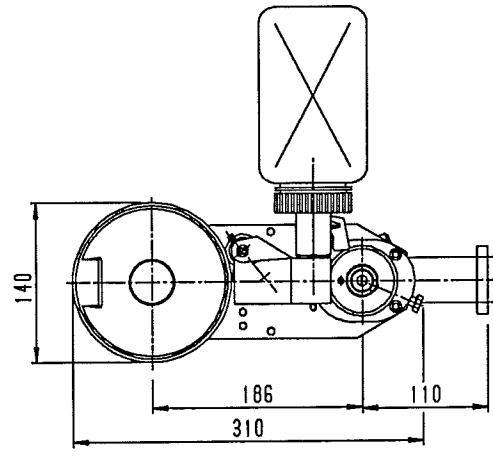

KORTHO-CODER HS 100/140
ART. REF.: 901275

DIMENSIONAL DIAGRAM
KORHO HS-CODERS
MODELS HSD AND HS
by korthofah

SEE FIGURE PREVIOUS PAGE FOR DIMENSIONS DEPENDING ON THE SETTING

Appendix E

Spareparts

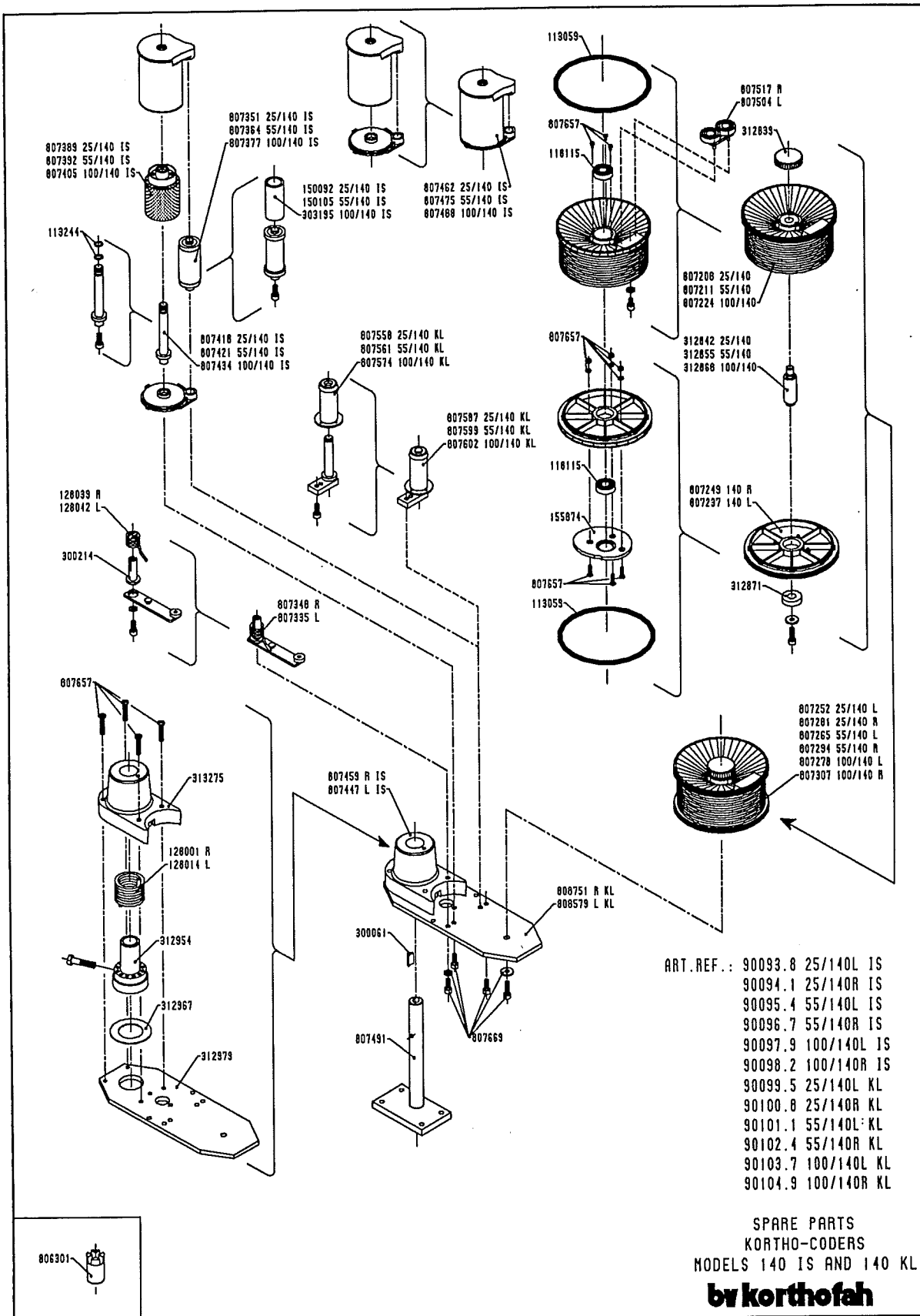

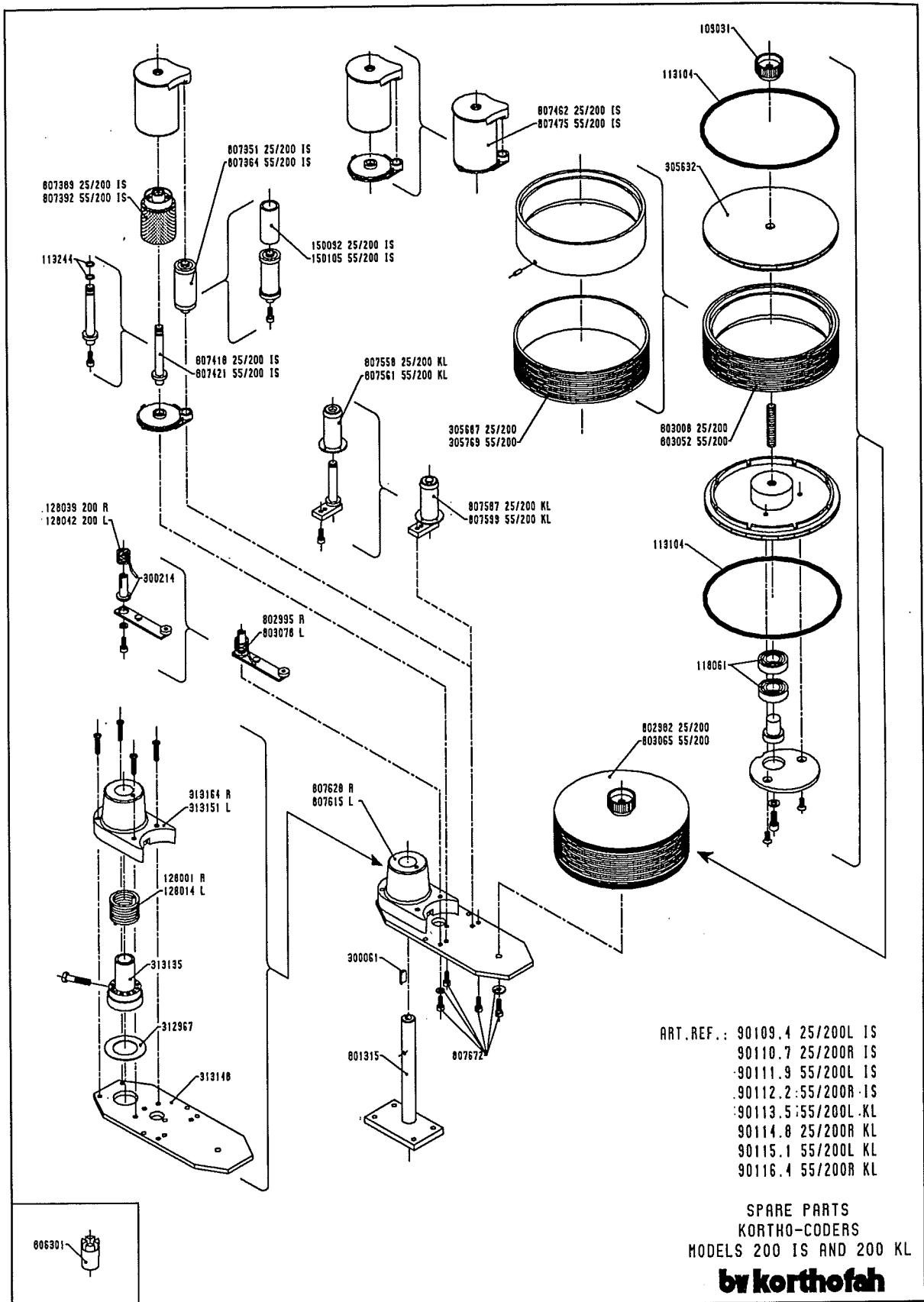

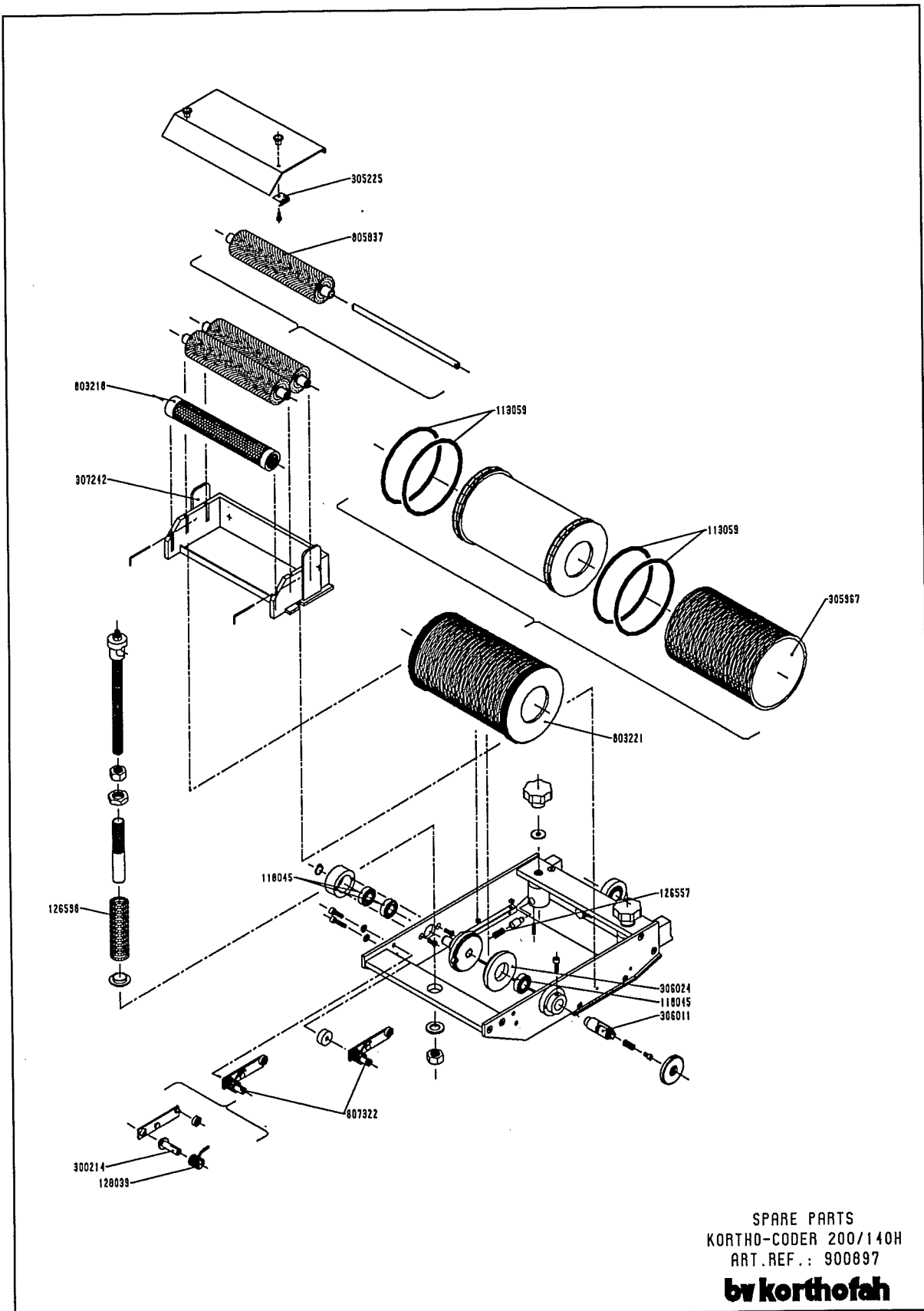

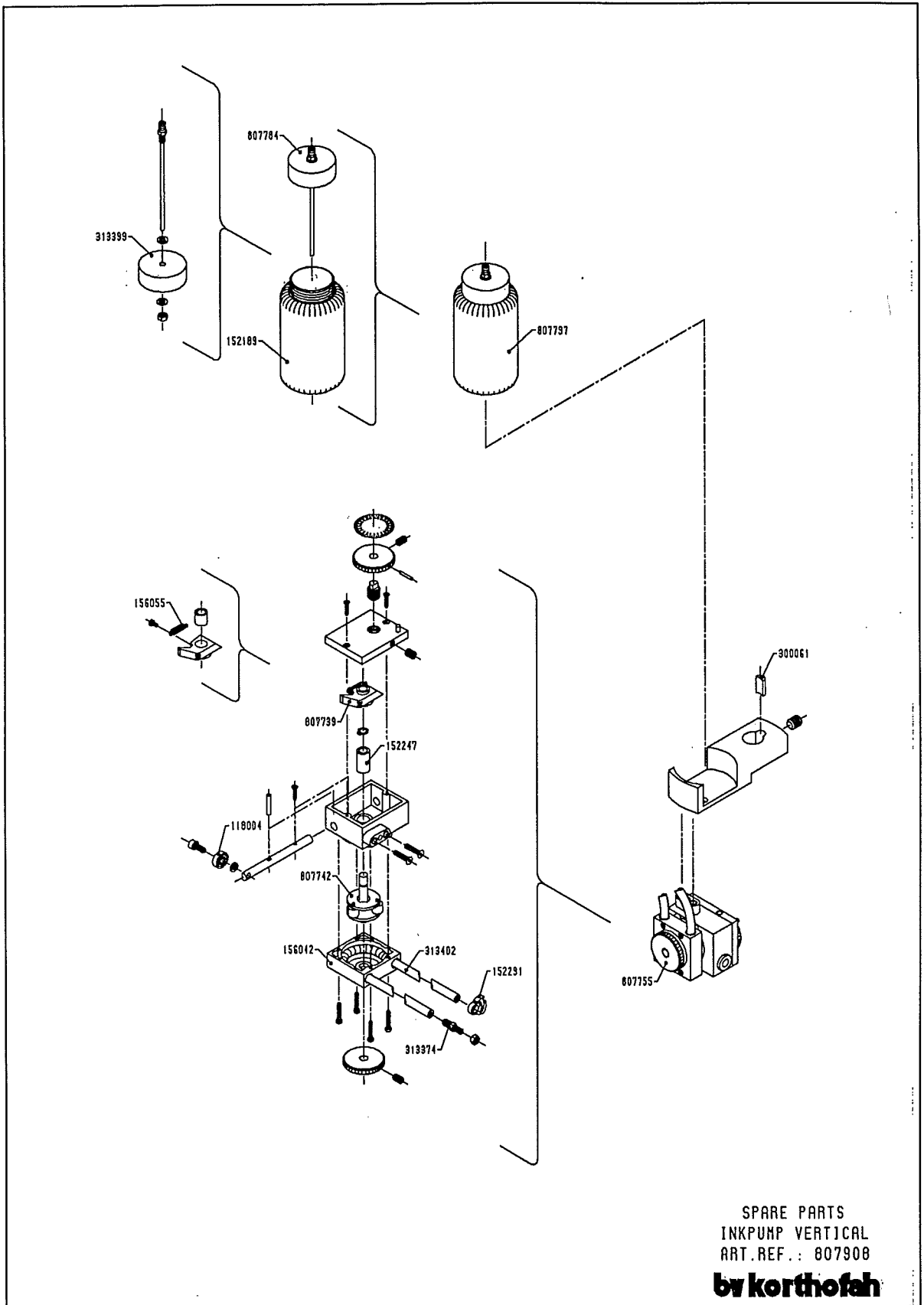

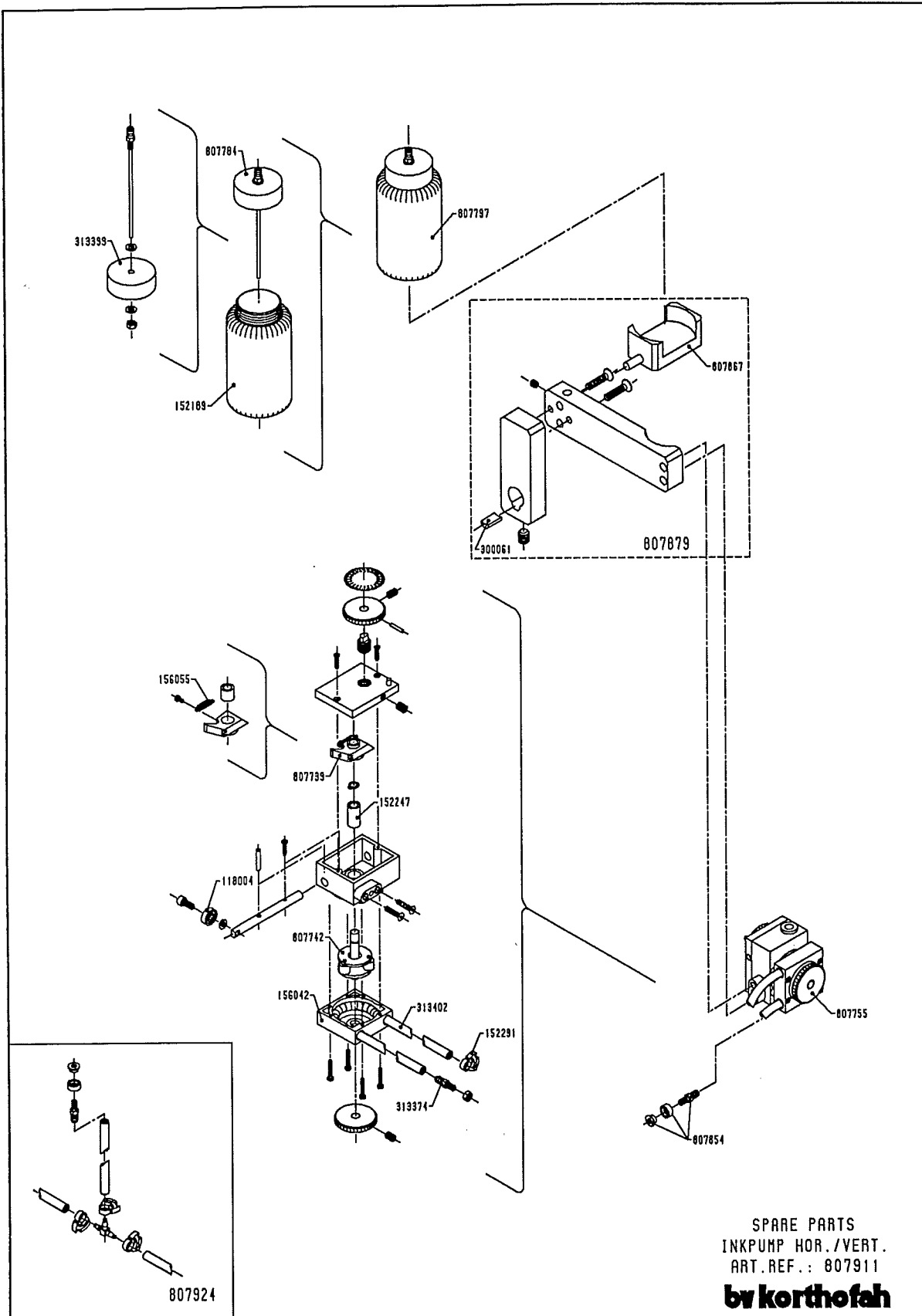

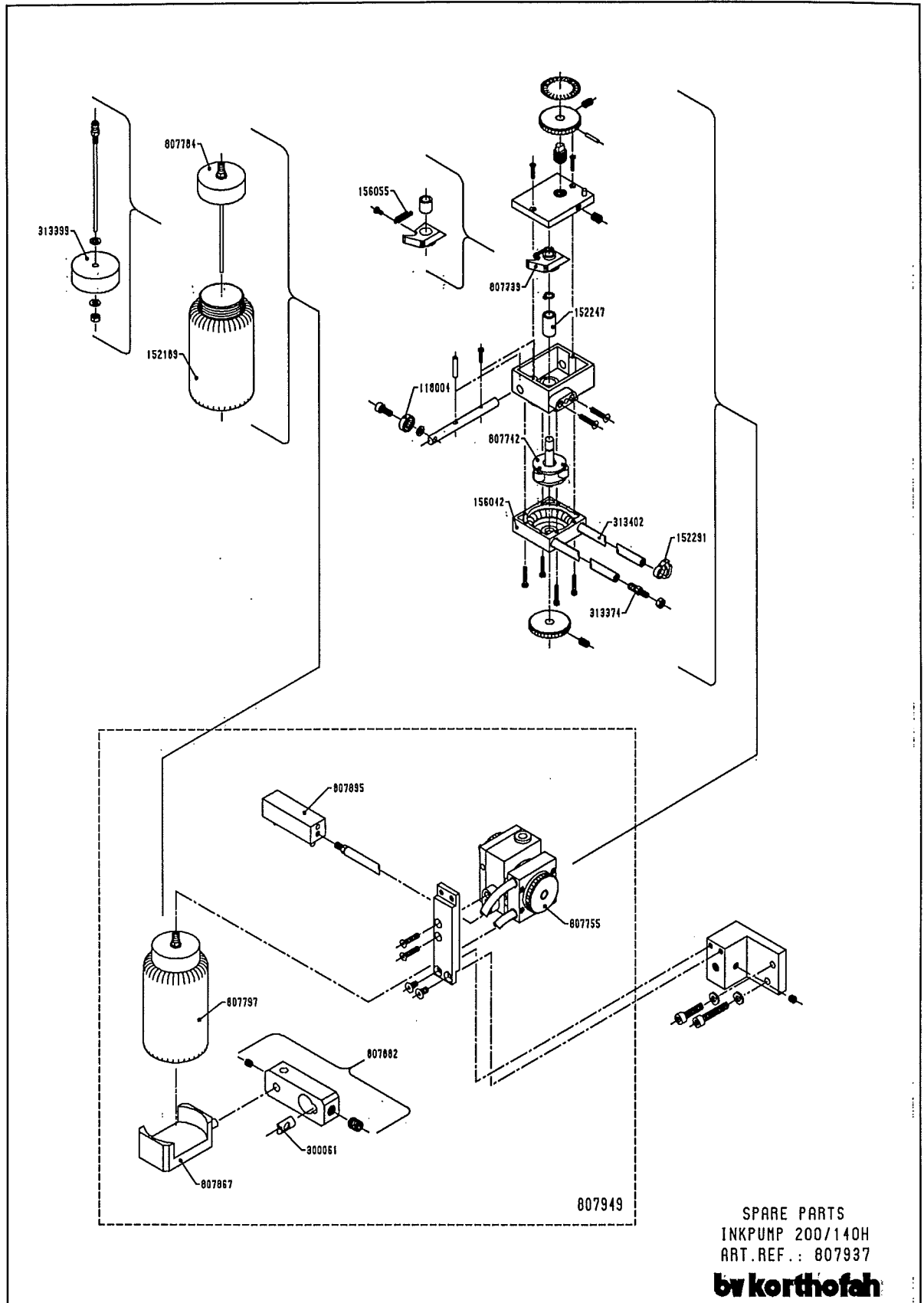

SPARE PARTS
 INKPUMP 200/140H
 ART. REF.: 807937
by korthofah

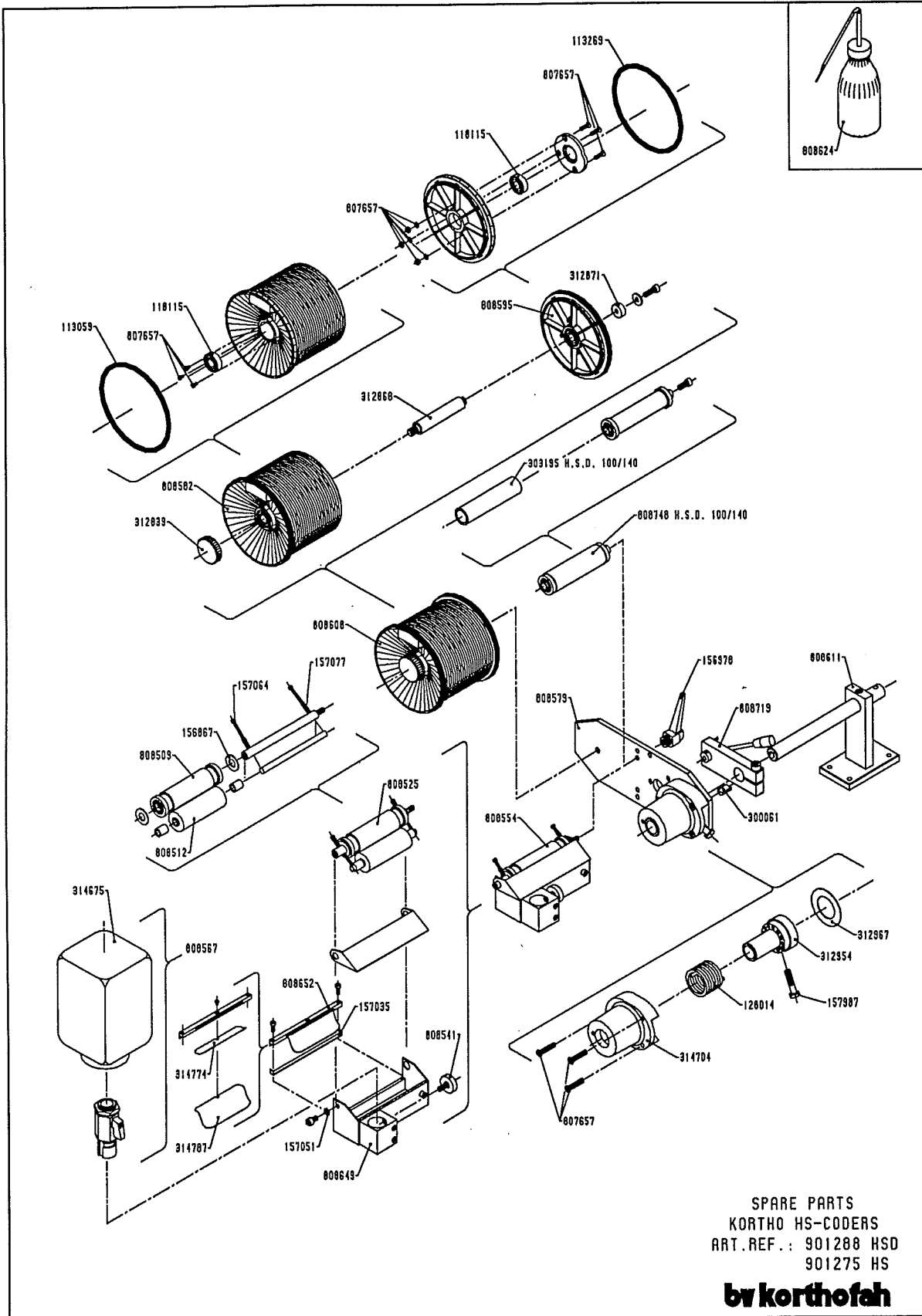

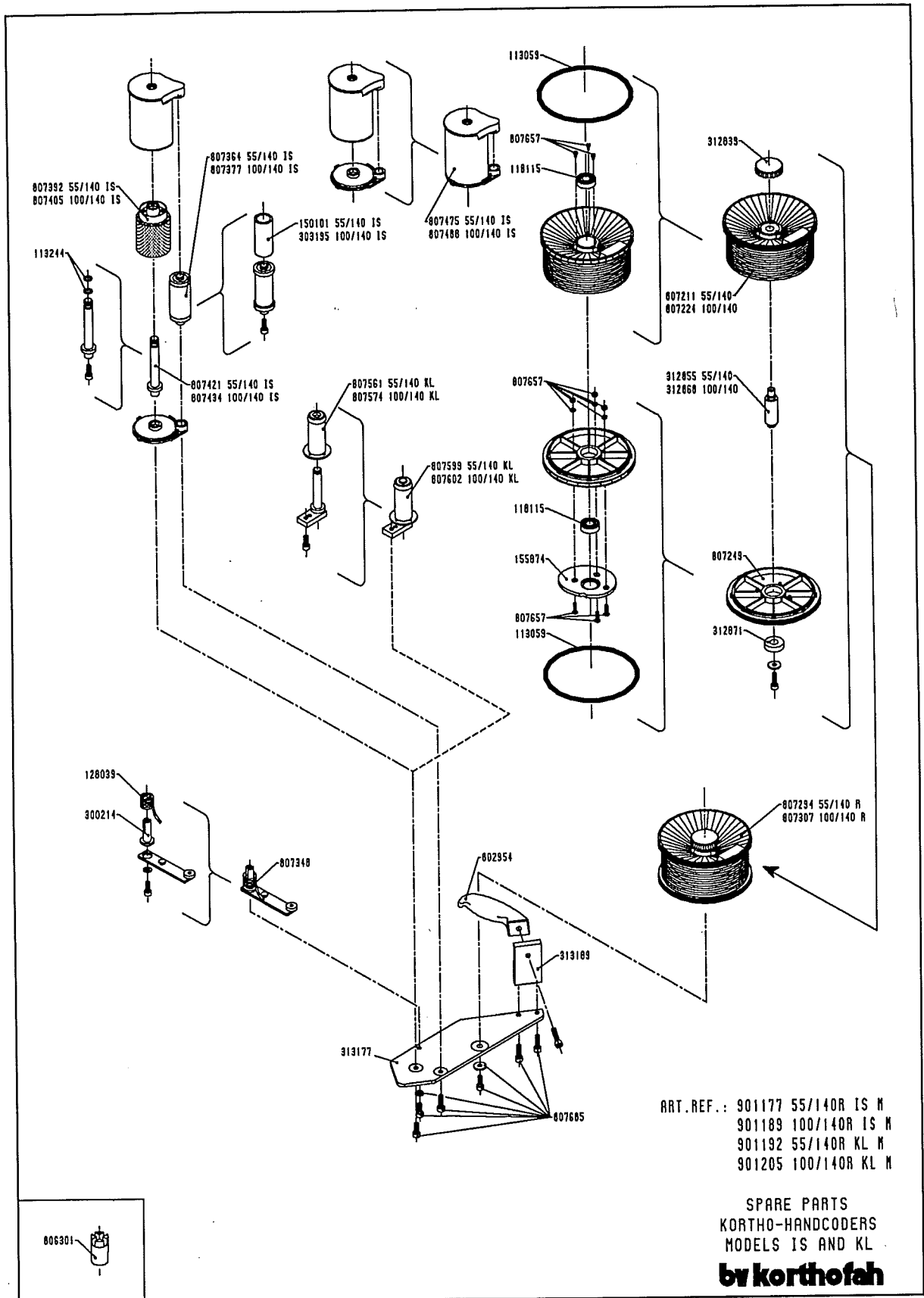

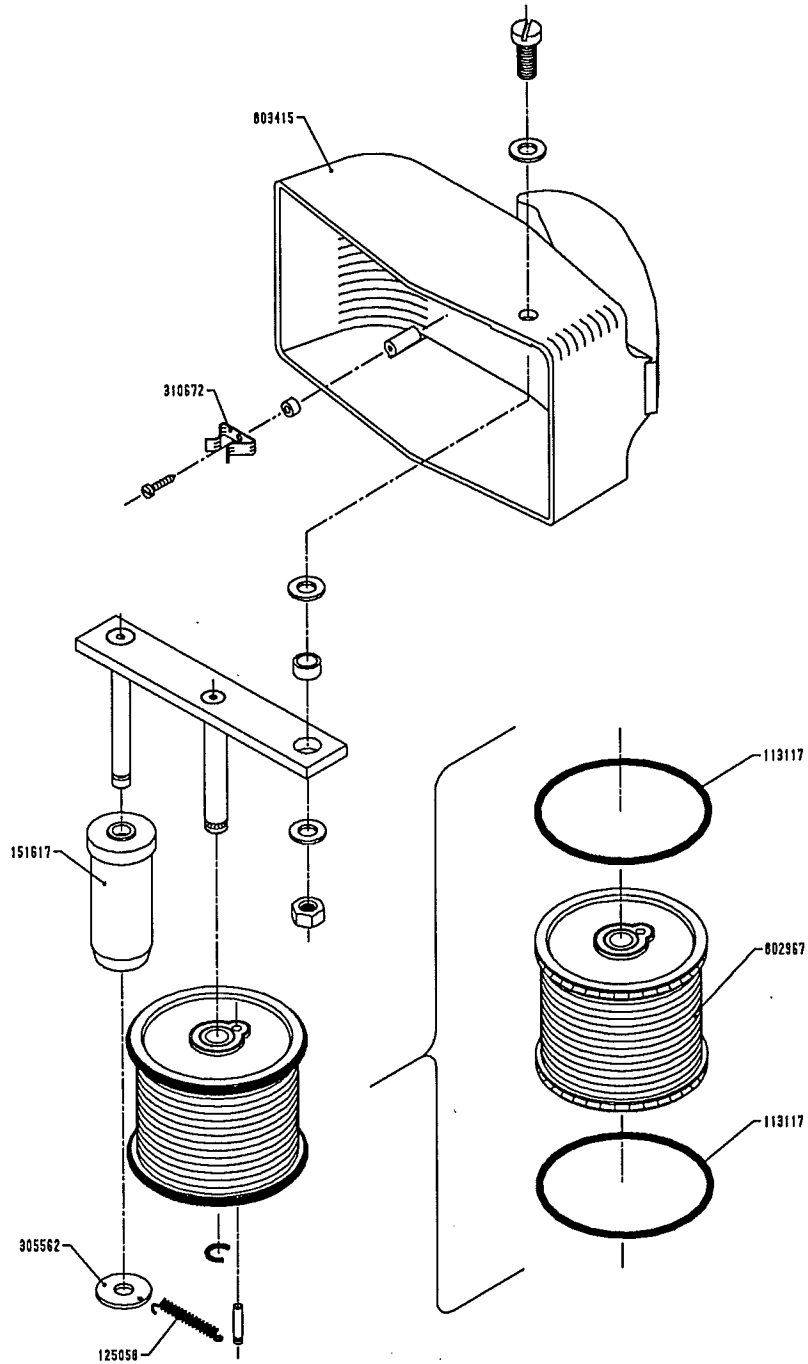

SPARE PARTS
 EURO ROLL-PRINTER 50/76
 ART. REF.: 900839

by korthofah

EC-DECLARATION OF AGREEMENT

(according to appendix II A of the machine guideline)

We:

B.V. Korthofah
Lageweg 39
2222 AG Katwijk Zh
Netherlands

declare out of our own responsibility that the product:

Kortho coder

that is the machines with the model numbers and specifications:

900938	900941	25/140	IS	left/right
900954	900967	55/140	IS	left/right
900979	900982	100/140	IS	left/right
900995	901008	25/140	KL	left/right
901011	901024	55/140	KL	left/right
901037	901049	100/140	KL	left/right
901094	901107	25/200	IS	left/right
901119	901122	55/200	IS	left/right
901135	901148	25/200	KL	left/right
901151	901164	55/200	KL	left/right
900897		200/140H	IS	plain-coder

possibly equipped with an inkpump which typenumbers are:

807908 inkpump vertical
807911 inkpump hor./vert.
807937 inkpump plain-coder

for which this declaration is meant, complies with the rules and regulations or otherwise conclusive documents listed below:

NEN-EN 292-1, 2nd. printing, april 1994
NEN-EN 292-2, 2nd. printing, april 1994
onw. NEN 5509, august 1993

according to the regulations of:

the machine guideline 89/392/EEC, wherein incorporated 91/368/EEC, 93/44/EEC and 93/68/EC

M.P.J.J de Groot
director

Katwijk Zh, Netherlands, 27th january 1995

N.B. To all other coders that are mentioned in the manual but are not listed here, the machine guideline does not apply.